

# IEEE Recommended Practice for General Principles of Temperature Measurement as Applied to Electrical Apparatus

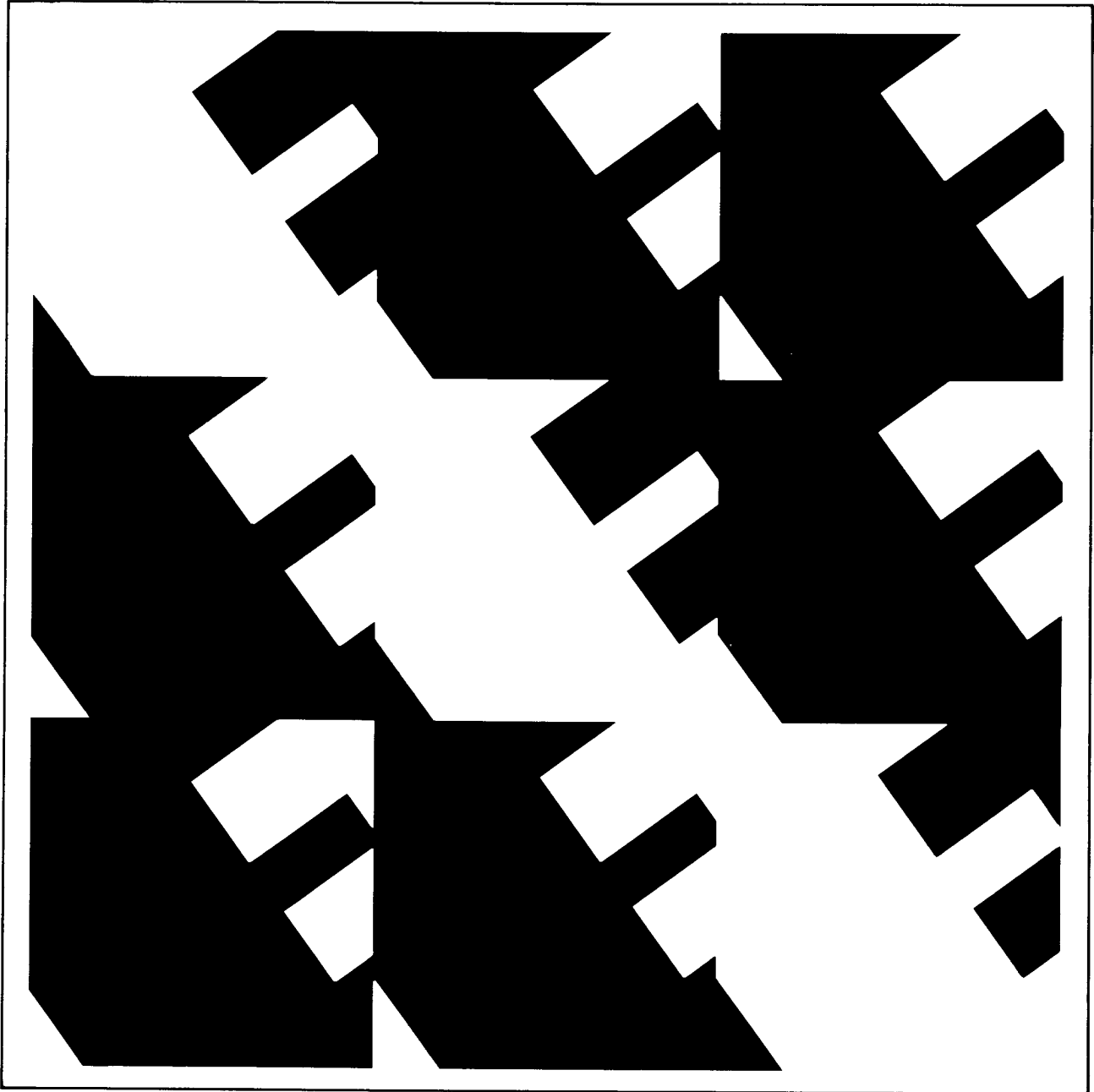

IEEE Std 119-1974



Published by The Institute of Electrical and Electronics Engineers, Inc 345 East 47th Street, New York, NY 10017, USA

January 20, 1975

SH11197



**IEEE**  
**Std 119-1974**  
(Revision of  
IEEE Std 119-1966)

**IEEE Recommended Practice for  
General Principles of  
Temperature Measurement as Applied to  
Electrical Apparatus**

Sponsor  
**Power System Instrumentation and Measurements Committee  
of the  
IEEE Power Engineering Society**

© Copyright 1974 by

**The Institute of Electrical and Electronics Engineers, Inc.**

*No part of this publication may be reproduced in any form,  
in an electronic retrieval system or otherwise,  
without the prior written permission of the publisher.*

Approved February 22, 1973

**IEEE Standards Board**

**Robert D. Briskman, *Chairman***

**Sava I. Sherr, *Secretary***

Stephen J. Angello  
Saul Aronow  
James E. Beehler  
Richard Brereton  
Warren H. Cook  
Louis Costrell  
Jay Forster

Joseph L. Koepfinger  
William R. Kruesi  
Benjamin J. Leon  
Donald T. Michael  
Voss A. Moore  
James D. M. Phelps  
Saul W. Rosenthal  
Gustave Shapiro

Ralph M. Showers  
Robert A. Soderman  
Frederick G. Timmel  
Leendert van Rooij  
Robert V. Wachter  
Bruno O. Weinschel  
William T. Wintringham

## Foreword

(This foreword is not a part of IEEE Std 119-1974, General Principles of Temperature Measurement as Applied to Electrical Apparatus.)

In the preparation of this document the subcommittee made free use of the American Society of Mechanical Engineers publication PTC 19.3-1974, Part 3, Temperature Measurement, Instruments and Apparatus, and of several publications of the National Bureau of Standards. Portions of the texts and many of the figures have been used with only minor changes. The subcommittee is deeply appreciative of the permission granted by these organizations for this use of their publications.

Sections 4.2 and 4.3 are largely abstracted from corresponding sections of the ASME publication and the user with more than a general interest in these areas should consult that publication for a comprehensive discussion. The ASME publication also contains somewhat more extended coverage of the areas dealt with in Sections 4.4 and 4.5.

During the writing of this standard, the Temperature Measurements Subcommittee had the following membership:

### **F. R. Kotter, *Chairman***

R. P. Ager  
G. C. Barnes, Jr  
R. D. Crosier  
A. M. Curry

H. C. Dunbar  
A. M. Lockie  
J. J. Mikos  
H. Oetzmann

D. Robertson  
L. E. Smith  
J. A. Staley  
E. C. Whitney



## Contents

SECTION	PAGE
1. Scope .....	9
2. Definitions .....	9
3. General .....	10
3.1 Temperature Scales .....	10
3.2 Temperature-Measuring Techniques .....	10
3.3 Temperature Data Acquisition Systems .....	11
3.4 Installation .....	11
3.5 Embedded Detectors .....	14
3.6 Sources of Error .....	16
4. Temperature-Measuring Instruments .....	16
4.1 Liquid-in-Glass Thermometers .....	16
4.2 Filled-System Thermometers .....	24
4.3 Bimetallic Thermometers .....	31
4.4 Thermocouple Thermometers .....	33
4.5 Resistance Thermometers (Resistance Temperature Detectors) .....	46
5. Infrared-Radiation Thermometer Systems .....	51
5.1 Principles of Operation .....	51
5.2 Classification .....	51
5.3 Characteristics .....	52
5.4 Accessories .....	52
5.5 Application and Installation .....	53
5.6 Advantages and Disadvantages .....	53
6. Temperature Determination by the Change in Resistance Method .....	54
6.1 General Principles .....	54
6.2 Classification of Methods .....	54
6.3 Essential Considerations .....	59
6.4 Advantages and Disadvantages of the Change in Resistance Method of Temperature Determinations .....	61
7. Temperature-Sensitive Materials .....	61
7.1 Principles of Operation .....	61
7.2 Classification .....	61
7.3 Characteristics .....	62
7.4 Application and Installation .....	62
7.5 Advantages and Disadvantages .....	62
8. Measurement of Ambient Temperature .....	62
8.1 General .....	62
8.2 Sources of Error in Ambient-Temperature Measurements .....	63
8.3 Ambient-Temperature Measurements in Service .....	64
9. Bibliography .....	65

FIGURES	PAGE
Fig 1	Multiple-Sensor Automatic Data-Logging System . . . . . 14
Fig 2	Thermometer Wells . . . . . 15
Fig 3	Sheathed Thermocouples . . . . . 15
Fig 4	Installation of Embedded Detector . . . . . 16
Fig 5	Partial, Total, and Complete Immersion Thermometers . . . . . 17
Fig 6	Etched-Stem Liquid-in-Glass Thermometers . . . . . 17
Fig 7	Industrial Liquid-in-Glass Thermometers . . . . . 18
Fig 8	Approach to Temperature in Stirred Water Bath for Three Thermometers with Typical Response Times ( $t_r$ ) . . . . . 21
Fig 9	Thermometer Calibrated for Total Immersion and Used for Partial Immersion . . . . . 23
Fig 10	Filled-System Thermometer . . . . . 24
Fig 11	Fully Compensated Liquid, Mercury, or Gas Filled Thermal System . . . . . 25
Fig 12	Case-Compensated Liquid, Mercury, or Gas Filled Thermal System . . . . . 25
Fig 13	Vapor Pressure Thermal System, Class IIA . . . . . 25
Fig 14	Vapor Pressure Thermal System, Class IIB . . . . . 26
Fig 15	Vapor Pressure Thermal System, Class IIC . . . . . 26
Fig 16	Vapor Pressure Thermal System, Class IID . . . . . 26
Fig 17	Bulb Response Versus Bulb Outside Diameter in Water . . . . . 29
Fig 18	Bulb Response Rate in Air at Various Velocities . . . . . 30
Fig 19	Bimetallic Thermometer . . . . . 31
Fig 20	Thermocouple EMF Versus Temperature for Various Thermocouple Materials . . . . . 34
Fig 21	Thermocouple EMF – Temperature Relations . . . . . 35
Fig 22	Thermocouple Circuits . . . . . 35
Fig 23	Thermocouples Connected in Parallel . . . . . 36
Fig 24	Thermocouples Connected in Series . . . . . 36
Fig 25	Thermocouple – Potentiometer Circuit with Manual Reference-Junction Compensator . . . . . 39
Fig 26	Thermocouple – Potentiometer Circuit with Automatic Reference-Junction Compensator . . . . . 40
Fig 27	Circuit for Multiple Thermocouples Using a Single-Pole Selector Switch . . . . . 41
Fig 28	Elementary Circuit for Multiple Thermocouples . . . . . 42
Fig 29	Methods of Applying Thermocouples to Solids . . . . . 43
Fig 30	Thermocouple Reference-Junction Ice Bath . . . . . 44
Fig 31	Elementary Bridge Circuit for Resistance Thermometry . . . . . 47
Fig 32	Bridge Circuit for Avoiding Effects of Resistance at Moving Contacts . . . . . 48
Fig 33	Deflection Bridge Instrument, AC Supply . . . . . 49
Fig 34	Typical Multipoint Deflection-Bridge Resistance Thermometer Installation . . . . . 49
Fig 35	Crossed-Coil Temperature Indicator Operated from AC Source . . . . . 50
Fig 36	Circuits for Resistance Measurements by Drop-of-Potential Method . . . . . 54
Fig 37	Kelvin Bridge Circuit . . . . . 55
Fig 38	Circuits for Resistance Measurements by Drop-of-Potential Method with Circuit Energized . . . . . 56
Fig 39	Circuit with Capacitor Bias . . . . . 57
Fig 40	Seely's Method . . . . . 57
Fig 41	(A) Wheatstone Bridge Measurement with Potential Transformer in Bridge Arm Other than That with Unknown . . . . . 58
Fig 41	(B) Kelvin Bridge Measurement of Low-Valued Resistor Carrying AC Current . . . . . 58

FIGURES	PAGE
Fig 42	59
Fig 43	60
 TABLES	
Table 1	12
Table 2	13
Table 3	20
Table 4	20
Table 5	27
Table 6	38
Table 7	38
Table 8	38
Table 9	46



# IEEE Recommended Practice for General Principles of Temperature Measurement as Applied to Electrical Apparatus

## 1. Scope

The purpose of this document is to provide guidelines for the application of temperature-measurement techniques in measuring the operating temperature and temperature rise of electrical machines, instruments, and apparatus in common use. The guidelines are limited to measurement of temperatures below 500°C; however, some measurement techniques described herein are capable of measuring temperatures above 500°C, and these may be used at the higher temperatures after the validity and safety of the technique for the temperature involved have been confirmed. This recommended practice does not define permissible temperature rise or corrections since they must form a part of the standard for the particular apparatus involved. Should contradiction between guidelines stated herein and those in a specific apparatus test procedure or standard exist, the specific apparatus publication will govern.

Guidance for the selection of temperature limits in the rating of electrical apparatus is provided in IEEE Std 1-1969, General Principles for Temperature Limits in the Rating of Electric Equipment.

## 2. Definitions

**bimetallic thermometer.** A temperature-measuring instrument comprising an indicating pointer and appropriate scale in a protective case and a bulb having a temperature-sensitive bimetallic element. The bimetallic element is composed of two or more metals mechanically associated in such a way that relative expansion of the metals due to temperature change produces motion. (See SAMA, PMC-4-1, Bimetallic Thermometers, 2nd ed.)

**Bourdon.** A closed and flattened tube formed in a spiral, helix, or arc, which changes in

shape when internal pressure changes are applied.

**NOTE:** Bourdon tube, or simply Bourdon, has at times been used more restrictively to mean only the C-shaped member invented by Bourdon.

**embedded temperature detector.** An element, usually a resistance thermometer or thermocouple, built into apparatus for the purpose of measuring temperature. (Examination or replacement of an embedded detector after the apparatus is placed in service is usually not feasible.) (See IEEE Std 100-1972, Dictionary of Electrical and Electronics Terms (ANSI C42.100-1972).)

**filled-system thermometer.** An all-metal assembly consisting of a bulb, capillary tube, and Bourdon tube (see note under Bourdon) (bellows and diaphragms are also used) containing a temperature-responsive fill. A mechanical device associated with the Bourdon is designed to provide an indication or record of temperature. See Fig 10.

**infrared radiation thermometer.** An optical system that accepts electromagnetic radiation in the infrared portion of the spectrum and either concentrates it on a temperature-sensitive element, which in turn activates an indicating device, or transforms it into radiation in the visible spectrum.

**liquid-in-glass thermometer.** A thin-walled glass bulb attached to a glass capillary stem closed at the opposite end, with the bulb and a portion of the stem filled with an expansive liquid, the remaining part of the stem being filled with the vapor of the liquid or a mixture of this vapor and an inert gas. Associated with the stem is a scale in temperature degrees so arranged that when calibrated the reading corresponding to the end of the liquid column indicates the temperature of the bulb.

**resistance thermometer.** An electric thermometer that operates by measuring the electric resistance of a resistor, the resistance of which is a known function of its temperature.

The temperature-responsive element is usually called a resistance temperature detector. (The resistance thermometer is also frequently used to designate the sensor and its enclosing bulb alone, for example, as in platinum thermometer, copper-constantan thermometer, etc.) (See IEEE Std 100-1972.)

**response time.** The time required for the indication of a thermometer, which has been subjected to an essentially instantaneous change in temperature, to traverse 63 percent of the temperature interval involved. Following such a temperature change the indication of the thermometer may be expected to traverse 99 percent of the temperature interval in a period ranging from 5 to 8 time constants so defined, depending on the details of its construction.

**sensor.** That portion of a temperature-measuring system that responds to the temperature being measured.

**thermistor.** An electron device that makes use of the change of resistivity of a semiconductor with change in temperature. (See IEEE Std 100-1972.)

**thermocouple.** A pair of dissimilar conductors so joined at two points that an EMF (electromotive force) is developed by the thermoelectric effects when the junctions are at different temperatures. (See IEEE Std 100-1972.)

**thermocouple extension wire.** A pair of wires having such EMF-temperature characteristics relative to the thermocouple with which the wires are intended to be used that, when properly connected to the thermocouple, the reference junction is in effect transferred to the other end of the wires. [See ANSI C96.1-1964 (R1969), Temperature Measurement Thermocouples.]

**thermocouple leads.** A pair of electrical conductors that connect the thermocouple to the EMF measuring device. One or both leads may be simply extensions of the thermoelements themselves or both may be of copper, dependent on the thermoelements in use and upon the physical location of the reference junction or junctions relative to the measuring device.

**thermocouple thermometer.** A temperature-measuring instrument comprising a device for measuring EMF, a sensing element called a thermocouple that produces an EMF of magnitude directly related to the temperature difference between its junctions, and electrical conductors for operatively connecting the two.

**thermometer.** An instrument for determining the temperature of a body or space.

**thermopile.** A group of thermocouples connected in series aiding. (See IEEE Std 100-1972.)

### 3. General

**3.1 Temperature Scales.** By international agreement, the Kelvin scale is now accepted as the absolute thermodynamic scale. Because of the difficulties encountered in the practical realization of the Kelvin scale, a practical working scale, the IPTS-68 (International Practical Temperature Scale of 1968) is used throughout the world in scientific and industrial laboratories. In the range of temperatures pertinent to this guide, the IPTS-68 is defined by four fixed points: the normal boiling point of oxygen at  $-182.962^{\circ}\text{C}$ , the triple point of water at  $+0.01^{\circ}\text{C}$ , the normal boiling point of water at  $100^{\circ}\text{C}$ , and the normal freezing point of zinc at  $419.58^{\circ}\text{C}$ . Temperatures in the range  $-259.34$  to  $630.74^{\circ}\text{C}$  at other than these fixed points are defined in terms of a standard platinum resistance thermometer calibrated at these and other fixed points and using a specified equation for interpolation.

Temperatures on the IPTS-68 are expressed in degrees Celsius. Thermometers graduated on the Fahrenheit scale are calibrated with reference to the IPTS-68 using the following conversion formula: temperature in degrees Fahrenheit =  $9/5$  (temperature in degrees Celsius) + 32.

**3.2 Temperature-Measuring Techniques.** Temperature measurements are made for a variety of purposes. Accurate determination of the temperature of a component to a small fraction of a degree may be required, or determining the temperature to within a degree or

two may satisfy the need. The accurate determination of temperature in most cases requires carefully selected sophisticated equipment, carefully controlled sensor installation, and operation by trained technical personnel. This is expensive and for most purposes is not necessary. The most economical method that will supply information of the required accuracy should be adopted.

When a technique for determining the temperature of electrical apparatus is being selected, several factors must be considered.

- (1) Accuracy of the measurement required
- (2) Physical characteristics of the apparatus or component to be monitored (solid, liquid, gas, physical shape, size, etc)
- (3) Accessibility of the part to be monitored
- (4) Permanency of instrumentation to be installed (a short-term study or life-of-the-equipment installation)
- (5) Range of temperatures to be monitored
- (6) Location of readout device, local or remote
- (7) Electrical potential of component being monitored

The fundamental methods of temperature determination and their basic characteristics are given in Table 1. Specific directions and precautions in the use of these instruments are given in subsequent sections of this guide.

Temperature-measuring devices and techniques such as the magnetic, acoustic, and quartz thermometers that have not yet found application within the scope of this standard are not further discussed. (See [84] through [86].<sup>1</sup>)

Recommendations of specific techniques for typical applications are presented in Table 2.

**3.3 Temperature Data Acquisition Systems.** Thermocouple and resistance thermometers lend themselves to use where temperatures at several locations are to be monitored essentially simultaneously and over extended periods of time. Complete data-logging systems are commercially available for handling inputs from a few to several hundred sensors. The block diagram of a typical thermocouple system is shown in Fig 1.

<sup>1</sup> Numbers in brackets correspond to those in Section 9, Bibliography.

**3.4 Installation.** Where the sensor is immersed in the material whose temperature is to be measured, it obviously should be so located as to acquire and maintain as nearly as possible the temperature of the material. If the possibility of stratification, stagnation, or gradients exists, care must be exercised to choose a sufficient number of elements and to locate and install them properly, according to the requirements of the measurement to be made. Wherever practical, the sensor should be in direct contact with the medium being monitored rather than separated from it by a wall such as exists in a thermometer well. As nearly as possible the conditions of use of the thermometer with respect to insertion or immersion of the sensor and the arrangement of the leads or capillary should reproduce the conditions extant during its calibration.

In the measurement of surface temperature, the extent of insertion of the sensor will obviously be limited by the thickness of the material whose temperature is being measured. Thermocouples are generally used for this purpose. To aid in bringing the measuring junction to the temperature of the material surface, the junction should be peened or brazed into position when possible and a portion of the insulated thermocouple leads should be in intimate contact with the material surface. Care must, of course, be taken to insure that such an electrical connection to the surface does not result in shorting out a section of the measuring circuit. In the case of surface temperature measurements on piping, the leads should be wound around the pipe for at least four turns adjacent to the junction.

**3.4.1 Thermometer Wells.** If the absolute pressure of a confined fluid differs materially from atmospheric pressure, a thermometer cannot be directly immersed in the fluid but should be placed in a suitable thermometer well, as shown in Fig 2. This well is designed to give as high thermal conduction as possible in a radial direction and as low thermal conduction as possible in an axial direction. It must project far enough into the fluid to insure that, in spite of heat emission from its outer end, the bottom of the well attains substantially the temperature of the fluid. An overflow port, shown in Fig 2(A), aids in maintaining the intended depth of immersion of the thermometer.

Table 1  
Characteristics of Various Temperature-Measurement Techniques

Technique	Working Temperature Range (°C)	Estimated Uncertainty*	Access Required to Monitor	Type Readout	Adaptable to Recording Instrument	Special Notes
Liquid-in-Glass Thermometer	-200 to 500	0.01 to 2 °C	yes	direct visual sight of column height	no	primarily for fluids and surface temperatures of solids except when well or other provisions are made
Filled-System Thermometer	-240 to 670	0.5 to 1% of span	no	mechanical linkage to pointer	unusual	
Bimetallic Thermometer	-130 to 540	0.5 to 1% of span	no	mechanical linkage to pointer	no	
Thermocouple Thermometer	-180 to 1480	0.1 to 2 °C	no	electrical millivoltmeter	yes	
Resistance Thermometer	-260 to 750	0.001 to 2 °C	no	electrical circuit to meter	yes	
Infrared-Radiation Thermometer Systems <sup>†</sup>	-50 to 150 (to 3000 in special applications)	0.2 to 5 °C	no	meter or visual image display	no	used principally for detection of hot spots in electrical equipment
Change in Resistance Method	-20 to 250	depends upon winding resistance and method used	access to winding terminals required	mathematical conversion of resistance to temperature	no	for obtaining average winding temperatures only; winding normally is deenergized
Temperature-Sensitive Materials	38 to 600 (to 1700 in special applications)	1% for fusible types 10 to 15 °C for pigment types	access to surface being monitored is necessary	sensitive material physical change	no	temperature-sensitive materials change physical appearance when their calibrated temperature is reached; material applied to surface to be monitored

\* Estimated uncertainty varies with type of device, scale of readout device, quality, and temperature being determined.

† The characteristics given are those of instruments of importance in temperature measurements of electric apparatus.

**Table 2**  
**Temperature-Measurement Techniques for Specific Applications**

Application		Technique								
		Liquid-in-Glass Thermometer	Filled-System Thermometer	Bimetallic Thermometer	Thermocouple Thermometer	Resistance Thermometer	Infrared-Radiation Thermometer	Change in Resistance Method	Temperature-sensitive Materials	Embedded Detectors
Development Testing, Production Testing, Problem Investigation	Cooling medium (liquid or gas)	X	X		X	X				
	Transformer windings, motor and generator stator windings				X	X		X		X
	Windings of motor and generator rotors	While running						X		
		After stopping				X			X	
	Magnetic materials in transformers, motor, and generator stators				X					X
	Magnetic materials in rotors of rotating machinery						X		X	
	Cable				X			X		
Operating Machinery for Operational Records	Stationary windings of transformers, motors, generators, etc			X	X	X				X
	Cooling medium of transformers and large rotating machines	X	X	X	X	X				
	Static devices (electronic)				X		X			
Maintenance Checks and Failure Investigations	X	X	X	X	X	X	X	X	X	

For temperatures up to 200°C, the commonly used filling material for the thermometer well is mercury. A thin layer of oil on top of the mercury reduces the danger from the toxic effects of mercury vapor. Mercury should be used only in well-ventilated areas and cleanup of even small spills should be prompt and thorough. Mercury represents a hazard to equipment as well as to personnel. It amalgamates with copper and silver and their alloys, and extreme care should be taken to insure

that when mercury is used as a well-filling material, none of it is permitted to come in contact with the copper or brass portions of the apparatus or with the operator's rings.

For temperatures that are low and nearly constant, oil may be used as a filling material instead of mercury. Because it readily vaporizes, is subject to excessive convection currents, and has a low thermal conductivity, oil is not suitable if temperatures are high or rapidly varying.

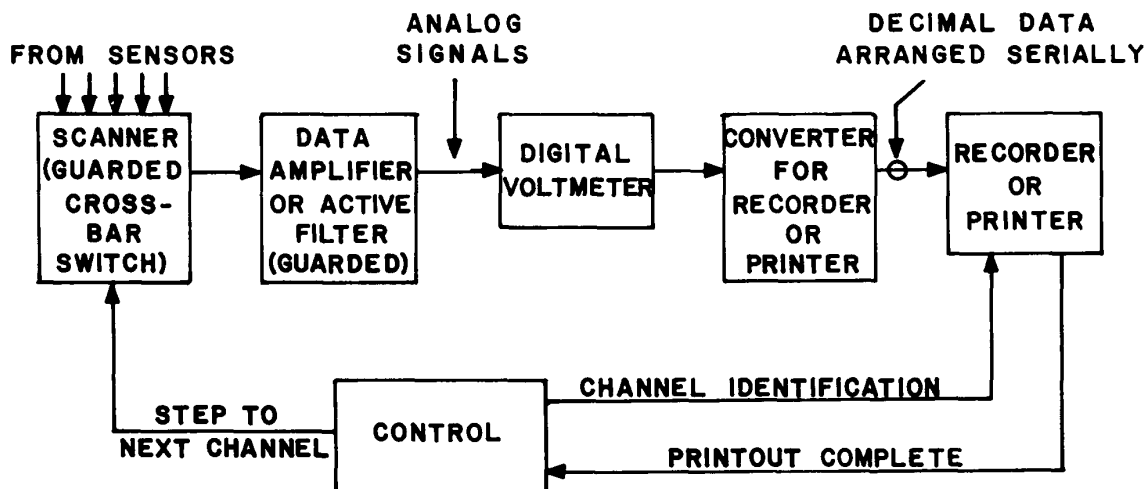

Fig 1  
Multiple-Sensor Automatic Data-Logging System

For temperatures between 200°C and 500°C, solder is a suitable filling material. Thermometers must be removed from cooling solder-filled wells before the solder solidifies. No filling is required in the packed sheath thermocouple (Fig 3).

While in general the use of wells is discouraged, where they must be used, the following precautions are necessary, particularly when the temperature being measured differs by more than 10°C from that of the surroundings.

(1) The material chosen for the wall of the well should be of the highest heat conductivity available consistent with other requirements placed upon it, for example, strength.

(2) The part of the well projecting beyond or outside the vessel must be as small as possible so as to eliminate heat transfer to or from surroundings.

(3) The exposed parts of the well should be covered with a suitable thermal insulating material. The vessel wall should be insulated for some distance from the thermometer well if the vessel is not already insulated, and if such insulation will not materially affect the temperature of the medium to be measured.

(4) The sensor should be in intimate thermal contact with the well. This may be accomplished by direct contact, as with thermocouples, by heat-transfer filling media or met-

allic sleeves for other thermometers that may be inserted in wells.

**3.4.2 Radiation Shields.** When it is necessary to place a temperature-sensing element in a gas at a location where it can receive radiation from, or radiate to, surfaces at temperatures materially different from that of the gas in which it is immersed, shields should be used to intercept the radiation and minimize the resulting errors.

**3.5 Embedded Detectors.** For temperature measurement by the embedded sensor method, it is important that an especially well-constructed sensor be used because, in most cases, replacement is impossible. Its construction must be such as to withstand the maximum temperatures attained during the manufacture and assembly, as well as during normal service, of the apparatus in which it is used. It must be installed in a manner to avoid interfering in any way with the operation of the apparatus. Each sensor should be protected by an enclosing sheath with leads being brought out to a suitable terminal board mounted on the apparatus.

In rotating machines, each sensor should be installed between insulating strips of such dimensions that the assembled unit is as wide as the slot and is somewhat longer than the sensor. The sensor should be located in the

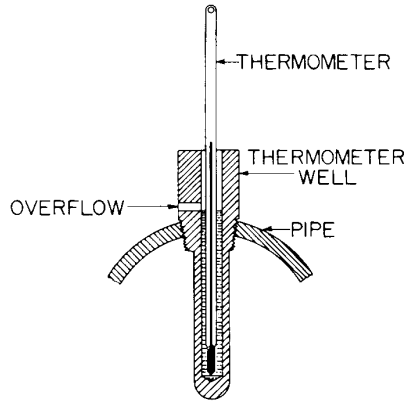

(A) Plain Mercury Well

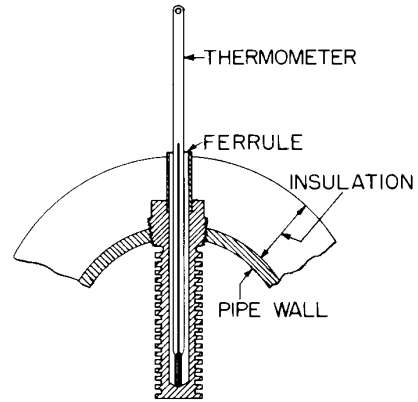

(B) Improved Finned Mercury Well

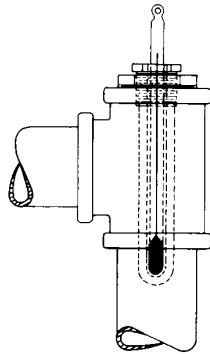

(C) Method of Installing Thermometer Wells in  
Pipe Lines Smaller Than 10 cm

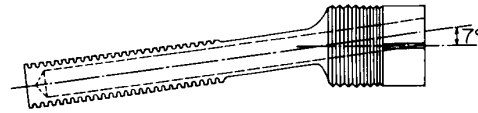

(D) Finned Well for Vertical Pipes

Fig 2  
Thermometer Wells

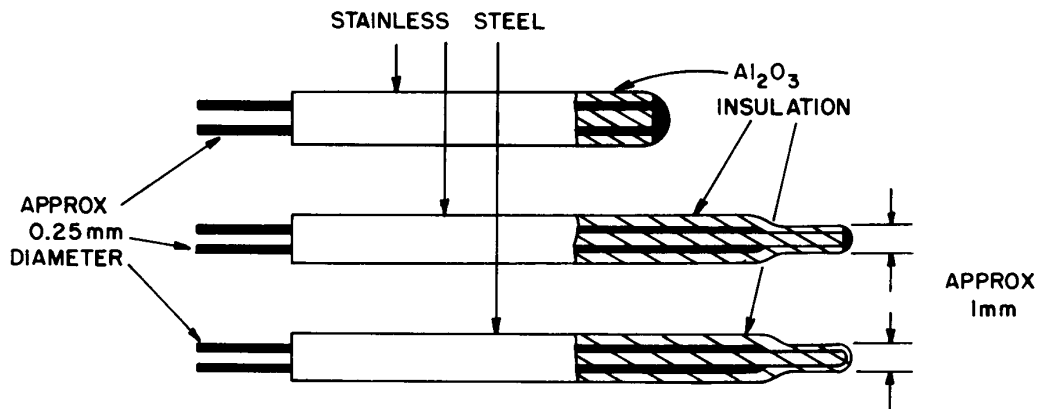

Fig 3  
Sheathed Thermocouples

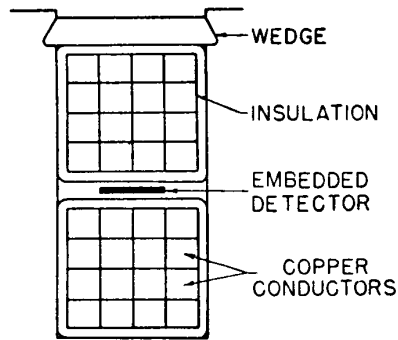

Fig 4  
Installation of Embedded Detector

middle of the slot width and, if possible, in intimate contact with the insulation of both the upper and lower coil sides, or in intimate contact with the insulation of the coil side that is nearer the air gap. See Fig 4.

Each sensor should be installed and its leads brought out in such a manner that it is effectually protected from contact with cooling air. If the length of the sensor is less than that of the core, access of air to the sensor should be prevented by suitable packing inserted between the coils and extending to the ends of the core.

The dimensions of the sensor should be such that its temperature represents the average temperature of the zone in which the measurement is desired.

**3.6 Sources of Error.<sup>2</sup>** In the case of measurements intended to be made under steady-state conditions, the mere attainment of a constant temperature reading is not in itself adequate. Because of the natural tendency toward temperature equalization, flow of heat from regions of higher temperature to regions of lower temperature will take place. For this reason, in general, introduction of the thermometer will alter the temperature it is desired to measure. The instrumentation should be designed to minimize this effect and appropriate corrections made where they can be evaluated.

It cannot be too strongly emphasized that the influence of dynamic effects must be rec-

ognized and evaluated. In temperature measurement, one of the important dynamic effects is associated with the lag in the measuring equipment in either responding to a change in temperature or indicating such change. Failure of an instrument to indicate a change in temperature may not in itself be positive proof that no change has taken place. The sluggishness of the measuring equipment in responding to change may serve to obscure the actual conditions.

In selecting and using temperature-measuring equipment, this dynamic or lag effect should be taken into consideration. Some of the factors to be considered are the following:

- (1) Heat capacity of the sensor
- (2) Heat capacity of any accessories such as wells or protecting tubes
- (3) Physical proportions and characteristics of the sensor or accessories that will influence the heat-transfer coefficients
- (4) Rate of temperature change in the material being measured
- (5) Mechanical or electrical characteristics of the temperature-measuring equipment

## 4. Temperature-Measuring Instruments

### 4.1 Liquid-in-Glass Thermometers.

**4.1.1 Principles of Operation.** The operation of a liquid-in-glass thermometer depends upon the coefficient of expansion of the liquid being greater than that of the bulb glass. As a consequence, an increase in the temperature of the bulb causes liquid to be expelled from the bulb, resulting in a rise in position of the end of the liquid column. The capillary stem attached to the bulb serves to magnify this change in volume.

#### 4.1.2 Classification.

**4.1.2.1 Etched-Stem-Type Thermometer (Laboratory and Chemical Thermometers).**

**4.1.2.1.1 Partial-Immersion Thermometer.** A partial-immersion thermometer [Figs 5 and 6(B)] is one that is designed to indicate temperature correctly when used with the bulb and a specified part of the stem exposed to the temperature being measured. The remaining part of the stem will be at the ambient temperature, usually different from the temperature being measured. Such thermom-

<sup>2</sup>ASME publication PTC 19.3-1974, Temperature Measurement, Instruments and Apparatus, contains an extended discussion of methods of calibrating thermometers and their associated measuring instruments.

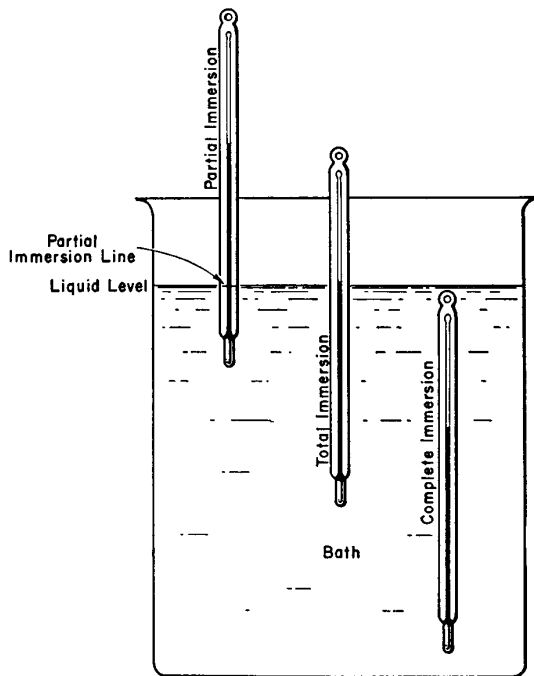

Fig 5  
Partial, Total, and Complete Immersion  
Thermometers

eters are marked with an immersion line to indicate the proper depth of immersion. The emergent stem refers to the length of liquid column and stem at the ambient temperature.

**4.1.2.1.2 Total-Immersion Thermometer.** A total-immersion thermometer [Figs 5 and 6(A)] is one that is designed to indicate temperature correctly when used with the bulb and the entire liquid column in the stem exposed to the temperature being measured, but with the gas above the liquid exposed to a temperature that may or may not be different.

**4.1.2.1.3 Complete-Immersion Thermometer.** A complete-immersion thermometer (Fig 5) is one that is designed to indicate temperatures correctly when the whole thermometer, including the expansion chamber, is exposed to the temperature being measured. In gas-filled thermometers the reading will be different for complete, as compared to total immersion, as a result of the effect of temperature on the gas pressure in the thermometer. The difference in readings under the two con-

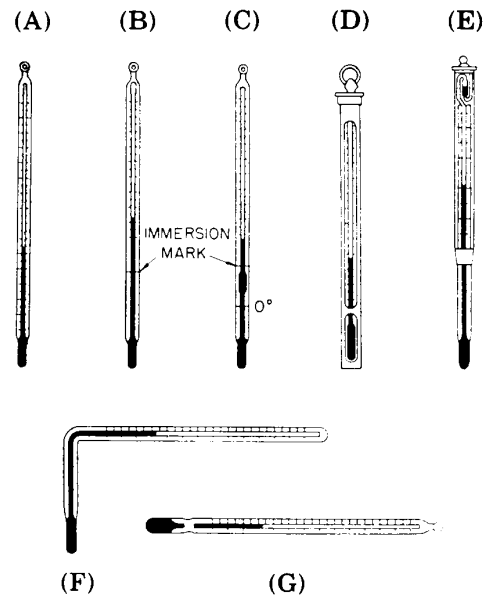

Fig 6  
Etched-Stem Liquid-in-Glass Thermometers  
(A) Total Immersion (B) Partial Immersion  
(C) Partial Range (D) Armored (E) Beckman  
Differential (F) Angle Stem (G) Maximum,  
Registering

ditions is particularly significant at high temperatures.

**4.1.2.1.4 Partial-Range Thermometer.** A partial-range thermometer [Fig 6(C)] has an enlargement in the capillary just above the bulb. Without requiring an excessive length of the emergent stem, this construction permits, over a limited temperature range, an expanded scale with large graduations. In partial-immersion thermometers, the enlargement must be well below the immersion line.

**4.1.2.1.5 Armored Thermometer.** A metal armor [Fig 6(D)], providing protection and mechanical support, is obtainable for etched-stem thermometers. It may be used where the increased time-lag and stem-temperature errors are permissible.

**4.1.2.1.6 Beckman Differential Thermometer.** The Beckman differential thermometer [Fig 6(E)] is usually made with a short-range interval such as  $5^{\circ}\text{C}$  and a very open scale having, for example,  $0.01^{\circ}\text{C}$  sub-

divisions. The range can be varied at will by changing the amount of mercury in the bulb, any excess being retained in a reservoir at the top.

**4.1.2.1.7 Registering-Type Thermometer.** The common form of liquid-in-glass thermometer is nonregistering and must be read while immersed in the medium whose temperature is being measured. Thermometers of a registering type are used for the measurement of temperature in locations where the thermometer can be observed only after it has been taken from the medium whose temperature is being measured. These thermometers are generally of the etched-stem type.

**4.1.2.1.7.1 Maximum-Registering Type.** The maximum-registering type [Fig 6(G)] contains mercury (or mercury-thallium alloy) under vacuum and indicates the maximum temperature to which the bulb has been exposed subsequent to resetting. Built into the bore just above the bulb is a constriction that allows mercury to squeeze through on rising temperatures, but prevents the mercury from returning to the bulb except when extraordinary force is applied, as by shaking toward the bulb.

**4.1.2.1.7.2 Minimum-Registering and Maximum-Minimum-Registering Types** The minimum-registering and combination maximum-minimum types usually use alcohol or an alcohol-creosote mixture and depend upon surface forces to move an index within the liquid column.

**4.1.2.2 Industrial-Type Thermometer.** In this type, the bulb and a portion of the stem are enclosed in a metal tube while the scale section is contained in an attached metal case (see Fig 7). The scale is engraved or printed on metal plates fastened to the inside of the case. The case opening is generally closed by a glass window. Industrial thermometers are available in a variety of stem lengths, case sizes, and case-stem angles. The bulb chamber or sensitive portion may be immersed directly in the medium whose temperature is being measured, or it may be inserted in a well (separable socket) [Fig 7(B)], which in turn is immersed. Where the thermometer is mounted in an essentially permanent manner, the extension of the bulb assembly incorporates a threaded swivel nut connection. Union bushing and flange connections are also available

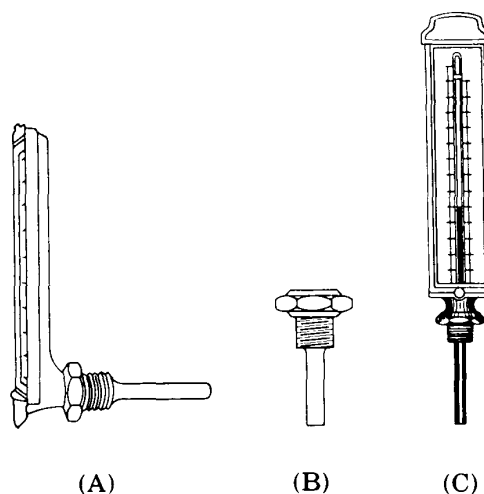

Fig 7  
Industrial Liquid-in-Glass Thermometers  
(A) Angle Stem (B) Separable Socket  
(C) Straight Stem

as alternative means of mounting. Some types are used at various immersions and are termed plain bulb style. No threaded connection is included with this type. Because of their massive metal parts, industrial thermometers are usually less suitable for tests of electrical apparatus than are etched-stem thermometers.

#### 4.1.3 Characteristics.

**4.1.3.1 Working Ranges and Choice of Liquid.** The working ranges for several liquids used are as follows:

Liquid	Range ( $^{\circ}\text{C}$ )
Mercury	- 38 to 500
Alcohol	- 70 to 120
Toluol	- 100 to 20
Pentane	- 185 to 20

In general, mercury thermometers are preferable to nonmetallic thermometers. Their accuracy is greater because, in contrast to the other liquids, mercury gives a more sharply defined meniscus and a smaller stem-temperature correction, and it does not wet the capillary. Mercury thermometers should not be used in locations where voltage gradients are too high for the safe introduction of extraneous conductors, or where the mercury released by accidental breakage would cause a

condition hazardous either to persons or to equipment, such as in the oil of a transformer.

**4.1.3.2 Sensitivity.** Sensitivity is determined by the cross-section area of the capillary bore and the proportion of that area to the volume of the bulb. Application conditions frequently limit the length of scale and the size of bulb. Practical limitations of tubing and thermometer manufacture are significant factors in establishing minimum bore diameters. Sensitivities far in excess of the long-term stability are misleading and generally are costly.

**4.1.3.3 Accuracy.** Accuracy is dependent not only upon the sensitivity or precision, but also upon the accuracy of calibration or standardization. Because of instability of bulb dimensions, a liquid-in-glass thermometer may undergo a change of calibration with age. This change is most conveniently detected by checking the 0°C point while the thermometer is in good thermal contact with melting ice. Therefore, a thermometer which has the 0°C point engraved on its stem [Fig 6(C)] is to be preferred. With well-designed thermometers, the accuracy of calibration attainable is a function of range and graduation interval. The NBS (National Bureau of Standards) reporting tolerances for such thermometers are listed in Tables 3 and 4.

NOTE: A packed slush made of shaved clear ice and distilled water is best for checking the 0°C point of a liquid-in-glass thermometer. All space between the ice shavings must be filled with water and any excess water on the top must be removed. Care must be taken to prevent contamination of the ice and water.

The values shown in Tables 3 and 4 in the column labeled "Tolerance" represent acceptable limits of error of high-quality thermometers without application of corrections. The values listed in the column headed "Accuracy" represent the limit of error to be anticipated when corrections are applied and when proper attention to such details as maintenance of correct immersion, avoidance of parallax, etc. is exercised in the use of the thermometers. The values shown in the column headed "Corrections Stated to" represent the limits to which NBS considers it appropriate to round off reported values.

With extreme care and attention to detail, the limits of accuracy listed in Tables 3 and 4 might be made smaller, but usually it is pref-

erable to use another type of measuring device, such as a platinum resistance thermometer, if a higher order of accuracy is required. Because of the uncertainty of measurement of the temperature of an emergent column, partial-immersion thermometers generally cannot be expected to give results of the same accuracy as otherwise equivalent design total-immersion thermometers. The etched-stem form is to be relied upon for results of the highest accuracy. The industrial and tube-and-scale forms are affected by heat conduction of the parts other than the glass tube. Such heat transfer is difficult to measure accurately and results in uncertainties in temperature measurement.

**4.1.3.4 Response Time.** The response time is dependent upon the dimensions and material of the thermometer bulb, the medium in which it is immersed, and the rate at which this medium is stirred. For instance, the response time when in the still air of a room would be perhaps 50 times that of the same thermometer when immersed in a well-stirred water bath.

Since the response time for mercury thermometers is not large, being from 2 to 10 s in a well-stirred water bath, it is not generally necessary to correct for it. For example, if two thermometers, one having a response time of 3 and another of 8 s, are read simultaneously in a bath whose temperature is rising at the rate of 0.001°C in 5 s, the former will read 0.001°C higher than the latter.

Fig 8 shows the approach of thermometer readings to the water bath temperature for 3 selected thermometers. For example, if the thermometer for which the response time is 2.2 s is initially at 25°C and then is immersed in a bath at 75°C, the thermometer reading will be within 0.05°C (0.1 percent of 50°C) of the bath temperature in 15 s and within 0.01°C in 19 s. The curve for 3.1 s response time was obtained for an ASTM (American Society for Testing and Materials) specification 56C calorimeter thermometer with a bulb diameter (outside) of 7.9 mm and a bulb length of 44 mm. The value of 2.2 s was found for an ASTM 7C thermometer having corresponding bulb dimensions of 5.4 and 12 mm. The third curve, for 1.7 s, was obtained for a bulb with corresponding dimensions of 5.4 and 34 mm. It is probable that most solid-stem

**Table 3**  
**NBS Tolerances for Celsius Partial-Immersion**  
**Mercury Thermometers**

Temperature range (°C)	Graduation Interval* (°C)	Tolerance (°C)	Accuracy† (°C)	Corrections Stated to (°C)
<b>Thermometers Not Graduated</b>				
Above 150°C				
0 up to 100	1.0 or 0.5	1.0	0.1 to 0.3	0.1
0 up to 150	1.0 or 0.5	1.0	0.1 to 0.5	0.1
<b>Thermometers Not Graduated</b>				
Above 300°C				
0 up to 100	1.0	1.0	0.1 to 0.3	0.1
Above 100 up to 300	1.0	1.5	.5 to 1.0	0.2
<b>Thermometers Graduated</b>				
Above 300°C				
0 up to 300	2.0 or 1.0	2.5	0.5 to 1.0	0.5
Above 300 up to 500		5.0	1.0 to 2.0	0.5

\*Partial-immersion thermometers are sometimes graduated in smaller intervals than shown in these tables, but this in no way improves the performance of the thermometers, and the listed tolerances and accuracies still apply.  
†The accuracies shown are attainable only if emergent-stem temperatures are closely known and accounted for.

**Table 4**  
**NBS Tolerances for Celsius Total-Immersion**  
**Mercury Thermometers**

Temperature range (°C)	Graduation Interval (°C)	Tolerance (°C)	Accuracy (°C)	Corrections Stated to (°C)
<b>Thermometer Not Graduated</b>				
Above 150°C				
0 up to 150	1.0 or 0.5	0.5	0.1 to 0.2	0.1
0 up to 150	0.2	0.4	0.02 to 0.05	0.02
0 up to 100	0.1	0.3	0.01 to 0.03	0.01
<b>Thermometers Not Graduated</b>				
Above 300°C				
0 up to 100	1.0 or 0.5	0.5	0.1 to 0.2	0.1
Above 100 up to 300		1.0	0.2 to 0.3	0.1
0 up to 100	0.2	0.4	0.02 to 0.05	0.02
Above 100 up to 200		0.5	0.05 to 0.1	0.02
<b>Thermometers Graduated</b>				
Above 300°C				
0 up to 300	2.0	2.0	0.2 to 0.5	0.2
Above 300 up to 500		4.0	0.5 to 1.0	0.2
0 up to 300	1.0 or 0.5	2.0	0.1 to 0.5	0.1
Above 300 up to 500		4.0	0.2 to 0.5	0.1

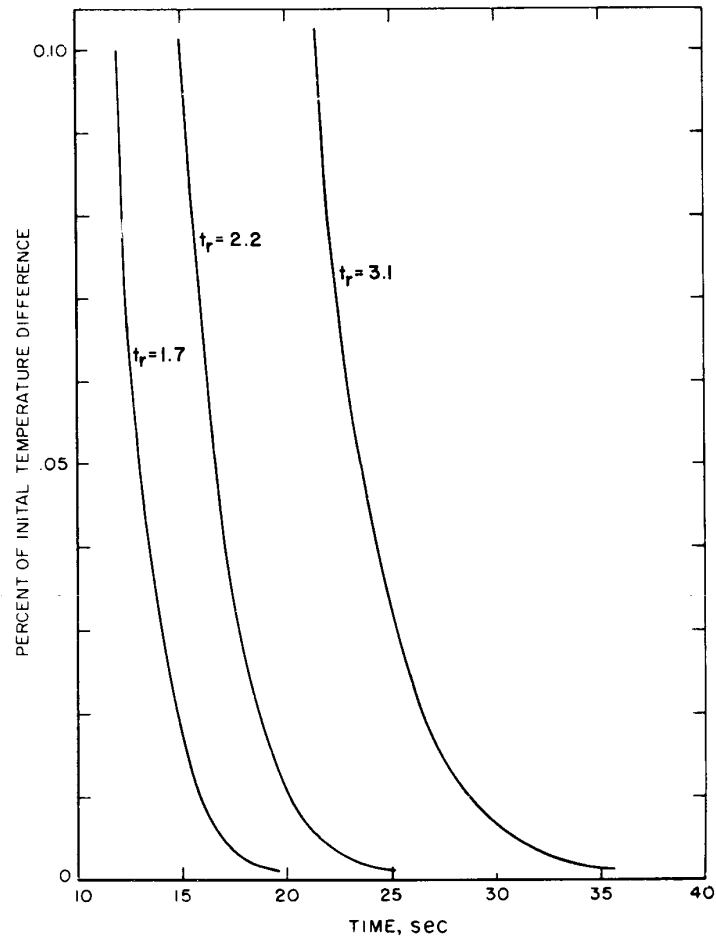

Fig 8  
Approach to Temperature in Stirred Water Bath for Three Thermometers with  
Typical Response Times ( $t_r$ )

thermometers of American manufacture will have values lying within the range covered by the 3 curves shown.

#### 4.1.4 Accessories.

**4.1.4.1 Wells or Sockets.** Wells or sockets are the major accessories for liquid-in-glass thermometers. For a general discussion of wells, see Section 3.4.1.

**4.1.4.2 Telescopes or Reading Glasses.** Telescopes or reading glasses are desirable in precision work to avoid parallax errors. The reading glass is usually clipped on the stem but must be positioned carefully.

#### 4.1.5 Application and Installation.

**4.1.5.1 Application to Solids.** The temperature in the interior of a solid can be mea-

sured by inserting the thermometer into a hole in the solid and filling the space between the solid and the thermometer with a suitable liquid (see Section 3.4).

Liquid-in-glass thermometers are not the most suitable for the accurate measurement of surface temperatures. Where its use is indicated, the thermometer should be tied to the solid by two cords located within 5 cm of each end. To provide good contact between the bulb and the solid, a spacer may be necessary under the stem or a heat-conducting shim under the bulb, dependent on the relative diameters of the bulb and stem. The bulb should be covered with several cubic centimeters of putty-like material. Too much is as bad as too

little. Neither putty nor any other low heat-conductivity material should come between the bulb and the surface of the solid.

Some varieties of putty are unsatisfactory because they contain excess volatiles which, in evaporating, cool the thermometer bulb. A putty which has been used successfully consists of whiting and mineral oil. Another is a material normally used as a dam in pouring babbitt. These putties remain plastic indefinitely and, under favorable conditions, are sticky enough to hold the thermometer in place. Also, at the conclusion of the test, they are easily removed. A special cement having relatively high thermal conductivity is also available.

The use of felt pads instead of putty is permissible if the error caused by the hygroscopic characteristic of the felt is found by test to be within acceptable limits. The pads must be fastened in place securely.

**4.1.5.2 Application to Free Gases.** Instances in which the entire thermometer is surrounded by the gas whose temperature is to be measured are discussed in Sections 8.2 to 8.2.2. The precaution described in Section 3.4 should be observed.

**4.1.5.3 Application to Confined Fluids.** Liquids, particularly if in motion, afford a very favorable coefficient of heat transfer to the thermometer bulb, and accurate measurement is possible by direct immersion of the thermometer in the liquid. For gases, the coefficient of heat transfer is far less than for liquids, and the difficulty of insuring that the bulb attain the temperature to be measured is correspondingly increased. The thermometer must be regarded as an element in a thermal circuit. Thermal conductance between the stem and the surrounding atmosphere may be comparable with that between the bulb and the gas to be measured. This condition may produce a serious error. It can be partly overcome by the use of a thermometer well (see Section 3.4) which, if properly designed and applied, increases the effective area of the bulb. However, to minimize radiation error, it is often desirable to keep the bulb area as small as possible. For these reasons, the most accurate measurement of temperature of confined gas is generally accomplished by the use of thermocouples, thermopiles, or special resistance thermometers.

#### 4.1.5.4 Sources of Error.

**4.1.5.4.1 Pressure Effects.** Since glass exhibits elastic properties, the volume of a thermometer bulb will change with change of pressure, either internal or external. Therefore, at the same temperature, the reading of a thermometer in a horizontal position will be different from its reading in a vertical position. Thermometer readings will change also with altitude or when the external pressure is changed in some other way. Changes of about  $0.1^\circ\text{C}/\text{atm}$  ( $0.1 \times 10^{-5}^\circ\text{C}/\text{Pa}$ )<sup>3</sup> have been found for many thermometers with bulb diameters between 5 and 7 mm. This value can be used with some confidence for estimating the probable effect of an external pressure change. The effect of change of internal pressure is about 10 percent greater. Formulas for both external and internal pressure coefficients have been derived by Guillaume (see [19]).

**4.1.5.4.2 Thermal Effects.** The glass in a mercury-in-glass thermometer is a supercooled liquid and is therefore subject to viscous flow with permanent dimensional changes under stress. These progressive changes are not likely to result in a change in calibration of more than  $0.1^\circ\text{C}$  for a good grade of glass if the thermometer has not been heated above  $150^\circ\text{C}$ . Below  $400^\circ\text{C}$  the change can be determined from an ice-point check.

**4.1.5.4.3 Stem-Temperature Correction.** Unless the mean temperature of the liquid contained in the thermometer stem is the same during use as it was during calibration, the reading does not agree with the actual bulb temperature. For mercury thermometers, under typical conditions of use at temperatures below  $100^\circ\text{C}$ , the error which would result from ignoring this effect would usually be less than  $1^\circ\text{C}$ . For nonmetallic thermometers under similar conditions, or for mercury thermometers that indicate temperatures of several hundred degrees Celsius, the error may exceed  $10^\circ\text{C}$ .

The correction for this error is more conveniently and accurately determined if the thermometer is calibrated for total immersion

<sup>3</sup> In accordance with the agreement reached by the Conférence Générale des Poids et Mesures and the ISO, the IEEE has adopted the pascal (Pa), formerly referred to as the newton per meter squared ( $\text{N}/\text{m}^2$ ), as the unit of pressure and stress.

instead of partial immersion. For total-immersion thermometers, the number of degrees Celsius, to be added algebraically to the thermometer indication, is

$$N(T-t)K$$

where

$N$  = the length of that part of the mercury column that is at a temperature different from that of the bulb; this length is expressed in terms of degrees on the thermometer scale

$T$  = the bulb temperature in degrees Celsius; as a first approximation, the indicated temperature may be used for  $T$

$t$  = the mean temperature in degrees Celsius of the mercury column whose length is  $N$

$K$  = the relative expansion coefficients of the liquid and glass of which the thermometer is constructed; for most purposes, the following values of  $K$ , applicable only to Celsius thermometers, are sufficiently accurate:

Liquid	$K$
Mercury	0.00016
Alcohol	0.001
Toluol	0.001
Pentane	0.0015

The determination of  $t$  may be made by the use of one or more short auxiliary thermometers attached to the stem of the main thermometer (Fig 9). The accuracy of this measurement is increased, and the magnitude of the stem correction decreased, if a glass tube about 2 cm in diameter is placed over the stems of the main and auxiliary thermometers.

**4.1.5.4.4 Magnetic Fields.** In ac magnetic fields of high intensity or high frequency, mercury thermometers are subject to error because of the induced eddy currents. The error in a mercury thermometer with a bulb diameter of 6 mm, caused by a 60 Hz flux density of 0.27 tesla (rms), is reported to be less than 0.5°C. At power frequencies it should be proportional to the square of the product of

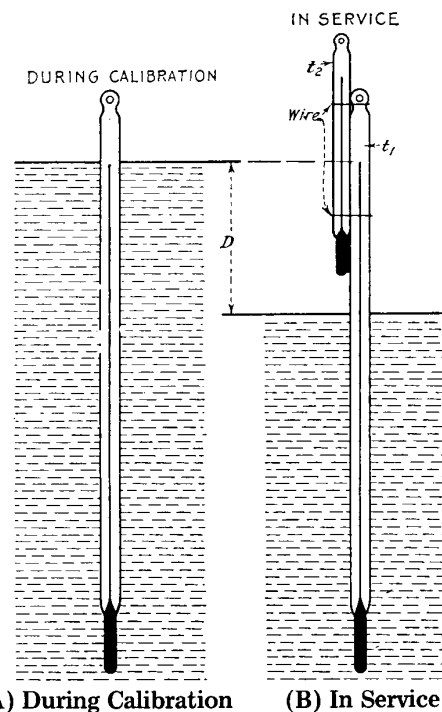

Fig 9  
Thermometer Calibrated for Total Immersion  
and Used for Partial Immersion

frequency and field strength. Where fields are capable of producing serious error, non-metallic thermometers should be used. In extreme cases, even these may be subject to errors caused by dielectric heating of the glass.

#### 4.1.5.4.5 Liquid Column Separation.

Gross errors may result from unnoticed separation of the liquid column. Such separation, which most frequently results after rough handling or shipment, in general does not represent permanent damage. One or a series of manipulations as indicated below is usually effective in rejoining broken columns.

(1) The thermometer bulb may be cooled to bring the liquid down into the bulb. Moderate tapping of the bulb on a firm object such as a paper pad or the application of centrifugal force usually proves effective in uniting the liquid.

(2) If the thermometer has an expansion chamber near its top the liquid can sometimes be united by warming the bulb until the column reaches the separated portion. Care is necessary to avoid filling the expansion cham-

ber completely since the pressure then developed might suffice to burst the bulb. This method should not be employed for high-temperature thermometers (above 250°C).

**4.1.5.5 Treatment of Data.** The observed temperature readings should be corrected for instrumental errors using the calibration correction values. Corrections at temperatures other than calibration temperatures should be determined by linear interpolation. Corrections for drift in calibration may be evaluated by periodic checking of the ice point or other convenient reference temperature and applying the observed change in correction at this temperature to all other correction values. Emergent-stem, lag, and external pressure corrections should be calculated and applied when necessary.

**4.1.6 Advantages and Disadvantages.**

**4.1.6.1 Advantages.** The advantages of liquid-in-glass thermometers are the following:

- (1) Available with wide variety of ranges, sensitivities, and accuracies
- (2) Simple to use
- (3) Calibration constant, except for drift in range span which can be measured readily by reference temperature check
- (4) Relatively inexpensive
- (5) Damage readily apparent, except for overranging at high temperatures
- (6) No auxiliary power supply required
- (7) Compact and easily portable

**4.1.6.2 Disadvantages.** The disadvantages of liquid-in-glass thermometers are the following:

- (1) Relatively fragile
- (2) Not adaptable to remote reading
- (3) The column may separate into segments, resulting in erroneous readings if not observed

**4.2 Filled-System Thermometers.<sup>4</sup>**

**4.2.1 Principles of Operation.** The sensor (bulb) contains a fluid which changes in physical characteristics (pressure or density) with temperature. This change is communicated to the Bourdon through a capillary tube (Fig 10). The Bourdon provides an essentially linear

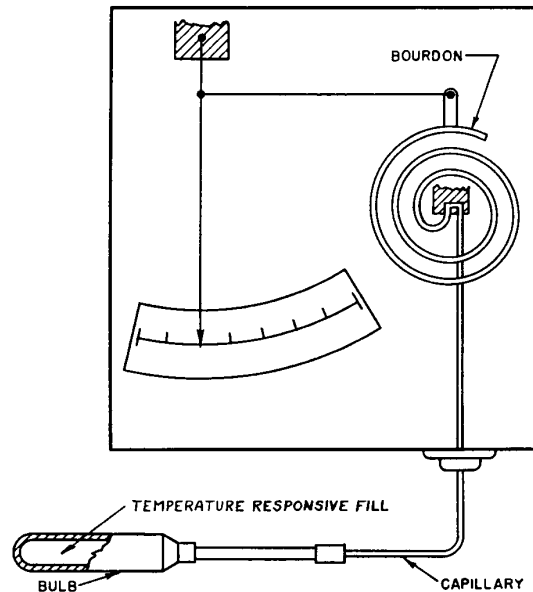

Fig 10  
Filled-System Thermometer

motion in response to an internally impressed pressure or volume change. The Bourdon motion, therefore, is directly a measure of the following:

- (1) Expansion of a liquid within the bulb
- (2) Pressure change of a gas within the bulb
- (3) Vapor pressure change of a volatile liquid within the bulb

**4.2.2 Classification.** Filled-system thermometers may be separated into two basic types: those in which the Bourdon responds to volume changes and those in which the response is to pressure changes.

**4.2.2.1 Liquid-Filled Systems.** The system that responds to volume changes is completely filled with a liquid [SAMA (Scientific Apparatus Makers Association) Class I]. The liquid in the bulb expands with temperature to a greater degree than does the bulb metal, thereby producing a net volume change which is communicated to the Bourdon. The system is usually compensated for ambient temperature effects with either of the following:

- (1) Full compensation (SAMA Class IA), the compensating means being a second thermal system minus the bulb, or equivalent means of compensation (see Fig 11)
- (2) Compensating means within the case only (SAMA Class IB) (see Fig 12)

<sup>4</sup>The material in Sections 4.2 and 4.3 is largely a condensation of the corresponding section of ASME publication PTC-19.3-1961. Consultation of that document is recommended to those with a vital concern in this area.

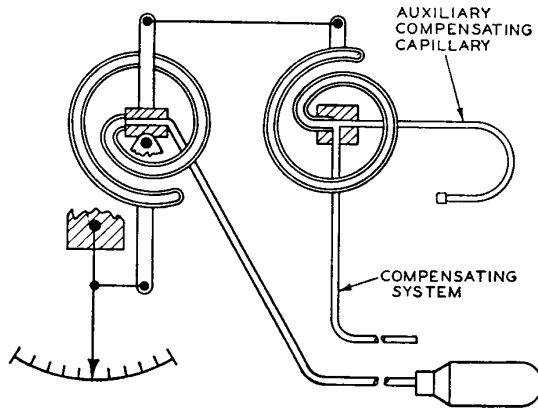

Fig 11  
Fully Compensated Liquid, Mercury, or  
Gas Filled Thermal System

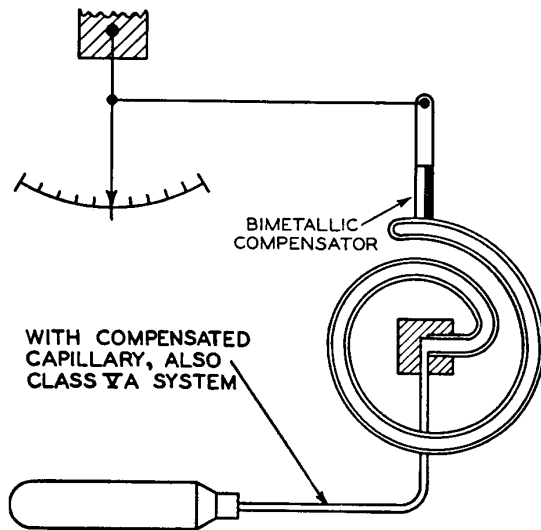

Fig 12  
Case-Compensated Liquid, Mercury, or  
Gas Filled Thermal System

4.2.2.2 *Pressure Systems.* The system that responds to pressure changes is either filled with a gas or is partially filled with a volatile liquid. Changes in gas or vapor pressure with changes in bulb temperature are communicated to the Bourdon.

4.2.2.2.1 *Vapor Pressure Thermal System.* A vapor pressure thermal system is a system partially filled with a volatile liquid and operating on the principle of vapor pressure. Four types are employed:

(1) The first type is designed to operate with the measured temperature above the

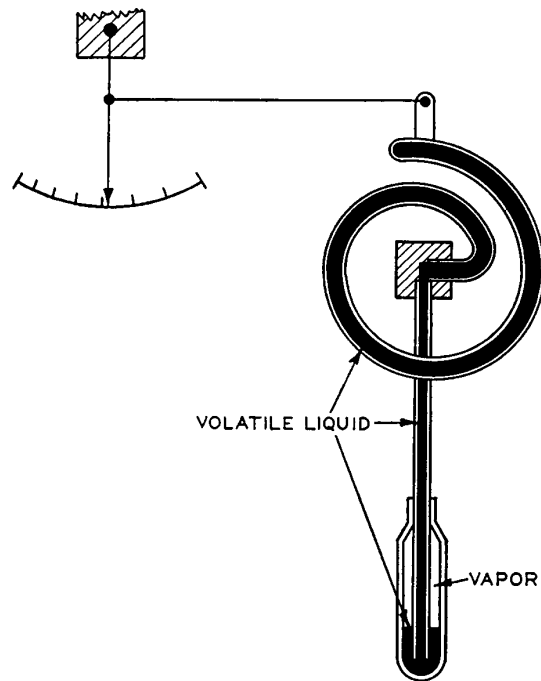

Fig 13  
Vapor Pressure Thermal System, Class IIA  
(For Use Where  $T_m > T_d$ )

temperature of the rest of the thermal system (SAMA Class IIA). See Fig 13.

(2) The second type is designed to operate with the measured temperature below the temperature of the rest of the thermal system (SAMA Class IIB). See Fig 14.

(3) The third type is designed to operate with the measured temperature above and below the temperature of the rest of the thermal system. This type normally requires a larger sensitive portion than either of the preceding types (SAMA Class IIC). See Fig 15.

(4) The fourth type is designed to operate with the bulb temperature above, below, and at the temperature of the rest of the thermal system. See Fig 16. In this type the volatile liquid is confined to the sensing bulb and a second relatively nonvolatile liquid is used to transmit the vapor pressure to the expansible device (SAMA Class IID).

4.2.2.2.2 *Gas-Filled Thermal System.* A gas-filled thermal system operates on the principle of pressure change with temperature change (SAMA Class III). The system is usu-

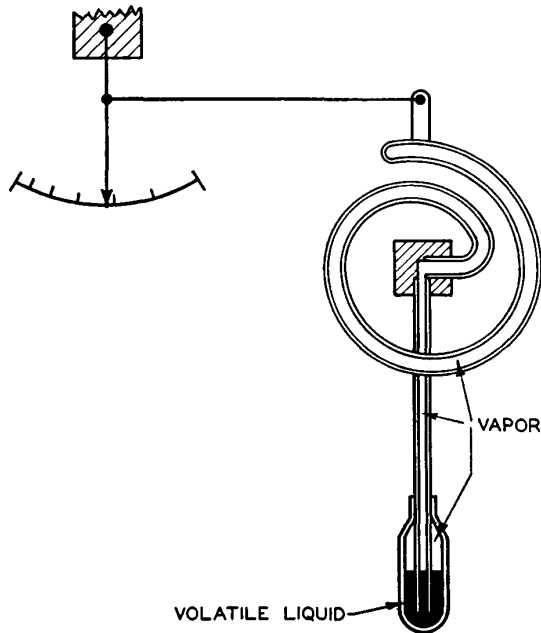

Fig 14  
Vapor Pressure Thermal System, Class IIB  
(For Use Where  $T_m < T_a$ )

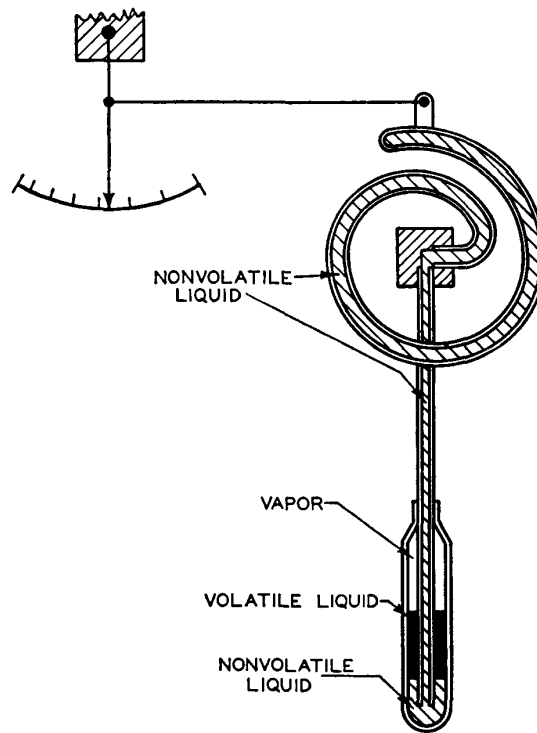

Fig 16  
Vapor Pressure Thermal System, Class IID  
(For Use Where  $T_m <, =, \text{ or } > T_a$ )

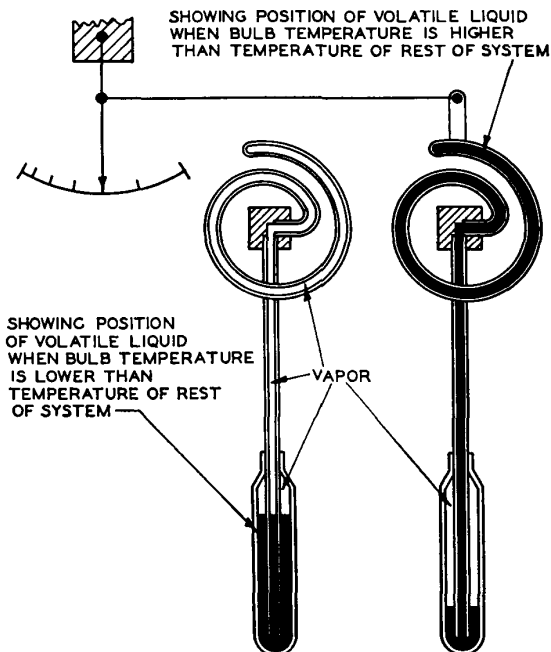

Fig 15  
Vapor Pressure Thermal System, Class IIC  
(For Use Where  $T_m < T_a$  or  $> T_a$ )

ally compensated for ambient temperature effects with either of the following:

(1) A second thermal system minus the bulb, or equivalent means of compensation (SAMA Class IIIA) (see Fig 11)

(2) Compensating means within the case only (SAMA Class IIIB) (see Fig 12)

#### 4.2.3 Characteristics

**4.2.3.1 Maximum and Minimum Temperatures.** The temperature limits shown in Table 5 are set by the properties of the thermometer fluid. In general, the lower limit is set by the freezing point of the fluid (or the critical point in the case of gases). The upper limit is set by chemical instability problems in the case of the organic liquids and by vapor pressure considerations in the case of mercury. The limits shown in parentheses in Table 5 are those obtained in special applications where the use of nonstandard fluids has permitted extension of the range.

**4.2.3.2 Range.** The range limitations for liquid systems shown in Table 5 are set by bulb-size considerations together with the in-

Table 5  
Comparison of Filled-System Thermometers

Operating Principle	Volumetric Systems				Pressure Systems	
	Organic Liquid Filled		Mercury		Vapor Pressure	Gas Filled
Type	Fully Compensated	Partially Compensated	Fully Compensated	Partially Compensated		
Class						
Low Temperature Limit	-180°C		-39°C, -54°C Hg-Th eutectic		-40°C	-240°C
High Temperature Limit	320°C		540°C (650°C)	320°C	540°C	540°C
Longest Span	330°C		560°C (670°C)	330°C	160°C	560°C
Shortest Span	14°C		22°C		22°C	56°C
Bulb Size						
Long span	smallest		intermediate		intermediate	large
Short span	intermediate		large		intermediate	large
Dial or Chart Divisions	equal	equal	equal	equal	larger at range top (also equal with separate linkage)	equal
Maximum Standard Capillary Length (approximate)	60 m	5 m	60 m	8 m	60 m	60 m
Capillary Temperature Compensation	dual capillary and Bourdons	none	compensated capillary or dual capillary and Bourdons	none	none necessary	generally none; rarely, dual capillary and Bourdons
Case Temperature Compensation	second Bourdon	bimetal strip	second Bourdon	bimetal strip	none necessary	bimetal strip; rarely a second Bourdon
Bulb Elevation Error	negligible	negligible	generally small	negligible	frequently large	negligible
Overrange Capacity	varies with length 200% to 0% range	100% of range	100% of range	100% of range	generally small	varies with range, up to 300% of range
Speed of Response (see Figs 17 and 18)	slowest in water, intermediate in air	intermediate	intermediate in water, slowest, in air	fastest to intermediate		varies widely with bulb diameter
Barometric Errors	negligible	negligible	negligible	negligible	usually small	usually small

herent nonlinearity of the expansion characteristics of the organic liquids. Nonlinearity is the principal range-limiting factor in the vapor systems. Minimum range in gas systems is set by internal system operating pressure considerations.

**4.2.3.3 Sensitivity.** Friction, endplay, and backlash in the mechanical assembly that transforms the Bourdon motion into pointer or pen motion usually sets the sensitivity limit for filled-system thermometers. The smallest detectable bulb temperature change is approximately 0.1 percent of the temperature span.

**4.2.3.4 Accuracy.** Filled-system thermometers are normally regarded as 1.0 percent instruments. This means that under most ambient conditions of the case or capillary the error will not exceed 1 percent of temperature span. However, many instruments are calibrated to higher accuracy and in indoor applications the maximum error is frequently specified as 0.5 percent of temperature span.

**4.2.3.5 Temperature Compensation.** Since the capillaries and Bourdons as well as the bulbs of filled-system thermometers are filled with actuating fluid, these portions of the system are sensitive to ambient temperature variations, and compensation for such variations is required. Full compensation is achieved by means of an auxiliary system identical with the primary system except that it has no bulb (see Fig 11). The two systems are connected in a differential mode.

Where the overall system design, operating conditions, and accuracy demands permit it, partial compensation, for the Bourdon volume only, is frequently adopted. This may take the form of a bimetallic strip (Fig 12).

The mercury system with full compensation is frequently supplied with a single capillary which is continuously temperature compensated along its entire length. This is achieved by employing a capillary with a precision bore enclosing a precision drawn Invar wire so that the expansion of the Invar wire and mercury equals the expansion of the surrounding capillary.

**4.2.3.6 Response Time.** The response time of a filled-system thermometer is usually determined by the response time of the bulb because the lag in the capillary is generally of the order of 1 s or less. The response time for

the bulbs of the various types of thermal systems in water, with a water velocity of 0.75 m/s, is approximated by the curves of Fig 17. The response time in air at various air velocities for typical bulb sizes may be estimated from the nomograph given in Fig 18.

**4.2.4 Accessories.** The Bourdon motion of filled-system thermometers is usually amplified by a simple linkage as shown in Fig 10 in order to drive the pointer of an indicator or the pen of a recorder. In dial gauges, greater angular motion of the pointer, usually 270° angular displacement, is achieved by a "movement." The most common movement employs a geared sector to drive a pinion to achieve angular amplification.

In temperature transmitters, the temperature signal is converted to a pneumatic or electrical signal and this signal in turn is communicated to a recorder or other readout device. The transmitters provide the means of transmitting temperature information over long distances. In the case of the pneumatic transmitter the Bourdon is usually replaced by a diaphragm which will exert a force responsive to bulb temperature. This force in turn is balanced by a feedback force of a pneumatic servo, the feedback force being generated by the transmitter pressure. Similarly, in an electrical transmitter the filled-system force is balanced by a force which is generated by an electric current. In other electrical transmitters the Bourdon motion directly operates the core of a differential transformer for ac output or the force from a Bourdon actuates a strain gauge for dc output.

#### **4.2.5 Application and Installation.**

##### **4.2.5.1 Sources of Error.**

**4.2.5.1.1 Zero Shift Error.** Filled-system thermometers are subject to mechanical abuse during shipment, which may cause an error in the calibration. The user, therefore, should check the instrument calibration and make corrections. A calibration error associated with shipment is usually confined to a "zero" shift, in which the entire range is shifted up or down, which may be corrected by a simple screw adjustment.

**4.2.5.1.2 Conduction Error.** The bulb of a filled system must be immersed to a depth sufficient to assure that conduction along the capillary will not significantly change the

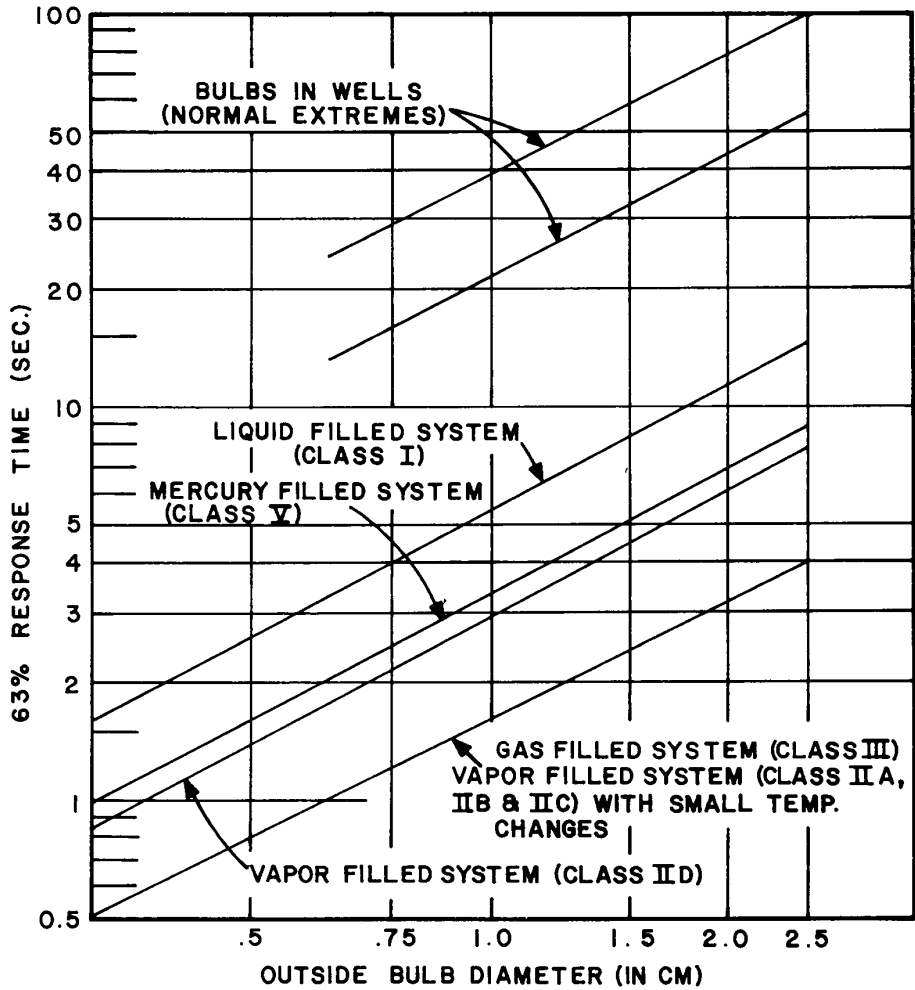

Fig 17  
Bulb Response Versus Bulb Outside Diameter in Water  
(Water Velocity of 0.75 m/s)

bulb temperature and thereby cause errors. In highly conducting media, such as low-viscosity liquids (that is, water), the bulb can be below the surface by only 1.5 cm; whereas, in poorly conducting media, such as high-viscosity oils or low-velocity vapor or gas, the bulb should be immersed up to a depth of 5 to 8 cm. When a bulb is in a well, particular attention should be paid to providing sufficient well length so that the top of the bulb is a minimum of 3 cm below the bottom of the well mounting threads. In a poorly conducting medium this length should be increased.

**4.2.5.1.3 Capillary Immersion Error.**  
The capillary of all types except the vapor system is temperature sensitive. Dual capillary systems frequently are used in liquid systems, and a compensated capillary is used in mercury systems. These compensating means are imperfect and the instrument reading will vary with length of capillary immersion. If the immersion length is greater than 20 cm, the immersion length should be specified to the manufacturer or the instrument should be adjusted by the user under the conditions of the application.

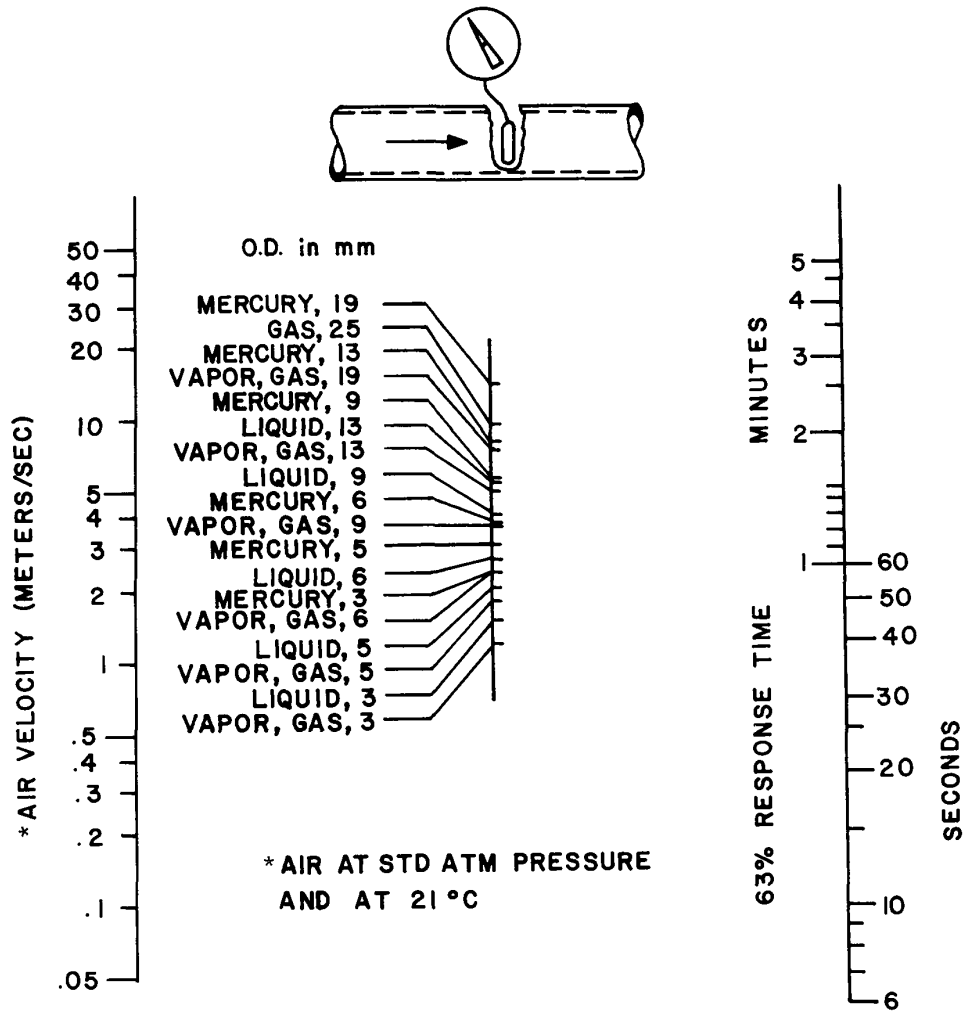

Fig 18  
Bulb Response Rate in Air at Various Velocities

4.2.5.1.4 *Bulb Elevation Error.* When the elevation of the Bourdon of a liquid system is changed relative to the bulb, the pressure head of the liquid within the system is also changed. This pressure redistribution causes a small volume change of the fluid and of the bulb and capillary, thereby causing a system error. A somewhat similar problem exists with the vapor-pressure system. In planning an installation of either system, if the levels of the bulb and Bourdon are to differ significantly, this fact should be made a part of the procurement specifications to permit the manufacturer to design and calibrate the system accordingly.

The elevation error is nonexistent in a gas system.

4.2.5.1.5 *Barometric Error.* This error is essentially nonexistent for systems operating on the volumetric principle, that is, for the liquid- and mercury-filled systems. Vapor and gas systems operating on the pressure principle are sensitive to barometric pressure changes by the ratio of barometric pressure change to the internal pressure change corresponding to the range. These systems therefore are designed to have a minimum pressure change of  $7 \times 10^5$  Pa (100 lb/in<sup>2</sup>) for the range of the thermometer. Since the maximum barometric pressure change is approximately

$\pm 3 \times 10^3$  Pa (0.4 lb/in<sup>2</sup>), this error will be equal to or less than 0.4 percent of range. The system calibration must, of course, take into consideration the average pressure existing at the altitude of the installation.

#### 4.2.6 Advantages and Disadvantages.

##### 4.2.6.1 Advantages.

- (1) System construction is rugged; amount of upkeep is generally minor
- (2) Low initial cost
- (3) Instrument can be located up to 75 m from point of measurement
- (4) Instrument needs no auxiliary power supply unless an electric chart drive is employed

##### 4.2.6.2 Disadvantages.

- (1) Bulb size may be too large for some applications
- (2) Maximum ranges are limited
- (3) Maximum temperature is limited
- (4) Failure of any component necessitates replacement of the entire system

### 4.3 Bimetallic Thermometers.<sup>4</sup>

**4.3.1 Principles of Operation.** The operation of a bimetallic thermometer depends upon the difference in thermal expansion of two metals. The most common type of bimetallic thermometer used is one in which a strip of composite material is wound in the form of a spiral or helix. The composite material consists of dissimilar metals which have been fused together to form a laminate. The difference in thermal expansion of the two metals produces a change in curvature of the strip with changes in temperature. The helical construction is used to translate this change of curvature to rotary motion of a shaft (Fig 19).

#### 4.3.2 Classification.

##### 4.3.2.1 Industrial-Type Thermometers.

These thermometers are generally supplied with 1/2 or 3/4 in (1.27 to 1.91 cm) external standard pipe thread connections. The bulb diameter varies from approximately 0.3 to 1 cm depending on the model, bulb length, and manufacturer. The 1/4 in (0.63 cm) diameter bulb is the most common. Bulb lengths from approximately 6 cm to 1.5 m are available.

Bimetallic thermometers are available with 18-8 type stainless steel protective shells which are corrosion resistant and will withstand pressures up to  $14 \times 10^6$  Pa (2000 lb/in<sup>2</sup>). Where pressure or corrosive conditions indicate the need for greater protection,

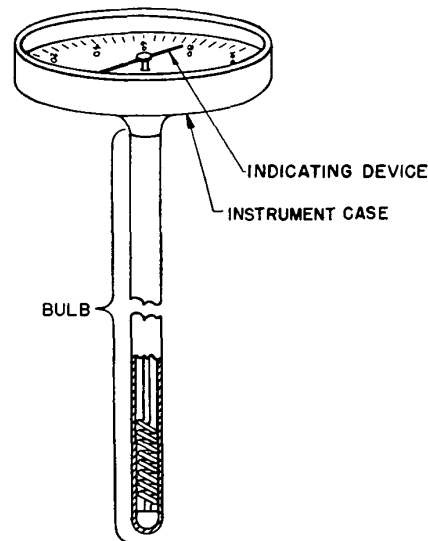

Fig 19  
Bimetallic Thermometer  
(Courtesy of Scientific Apparatus  
Makers Association)

wells of corrosion-resistant materials are available. Suitable plastic or lead coatings may be applied directly to the protective shell to overcome some corrosive conditions. Some manufacturers offer thermometers with fume-proof casings.

**4.3.2.2 Laboratory or Test-Type Thermometers.** These thermometers are characterized by higher accuracies than the industrial type and the absence of threaded connections. Straight and angle forms are available. In the straight form, a helical spring is generally employed to transmit the rotary motion of the shaft through an angle to the pointer. In the angle form, the rotary motion of the shaft is transmitted directly to the pointer.

Registering types of thermometers are equipped with friction-restrained extra pointers which indicate maximum or minimum temperatures. Damped thermometers which use silicone oil as a damping fluid in the stem to absorb shock and increase speed of response are available.

#### 4.3.3 Characteristics.

**4.3.3.1 Range.** Bimetallic thermometers are available in temperature ranges from  $-130^{\circ}$  to  $540^{\circ}$ C; however, they are not recommended for continuous operation above  $425^{\circ}$ C.

**4.3.3.2 Sensitivity.** Sensitivity is determined by the physical characteristics of the bimetallic element and the dimensions of the helix used. A maximum sensitivity of approximately 6° angular displacement per Celsius degree may be expected.

**4.3.3.3 Precision.** Precision of measurement of temperature with a bimetallic thermometer depends upon thermometer design and application conditions, as well as the care exercised to avoid parallax in reading the thermometer.

**4.3.3.4 Accuracy.** Accuracy is dependent upon the same factors as those which affect precision and, in addition, upon the accuracy of calibration and stability of the thermometer. A quality grade industrial-type thermometer, properly installed, may be expected to be correct within 1 percent of the instrument span. A properly installed laboratory-type thermometer may be expected to be correct within 1/2 percent of the instrument span.

**4.3.3.5 Response.** Response of bimetallic thermometers is a function of thermometer design and use conditions. Response characteristics of high-quality bimetallic thermometers are somewhat similar to those of liquid-in-glass thermometers. Industrial thermometers will show a response time of 3 to 4 s in a well-stirred water bath. However, the manufacturer can vary the response by the size of the bimetallic element, by the care he exercises in fitting the bimetallic element to the inside of the protective shell, and by the type of heat transfer material used between the bimetallic element and the shell. Therefore, bimetallic thermometers may have longer response times than specified above. Bimetallic thermometers that utilize a double helix exhibit substantially longer response times than those which use only a single helix.

**4.3.3.6 Mechanical Stability.** Mechanical stability of the bimetallic thermometer is affected by severe shock or vibrations which may distort the bimetallic element, thereby producing errors in indication. This distortion does not usually affect the thermal stability of the element, and the thermometer may be reset to perform with original accuracy, provided the element is not deformed to the point where friction has been introduced into the system.

**4.3.3.7 Thermal Stability.** Thermal stability of the bimetallic thermometer depends upon the metals used. Copper-invar and brass-invar combinations show marked plastic flow or drift above about 120°C. Nickel steel-invar thermometers do not exhibit measurable changes in characteristics following use up to 425°C; however, prolonged use at higher temperatures may produce shifts in calibration. In general, the calibration of a bimetallic thermometer which has been exposed to temperatures 50°C above its maximum scale point should be verified prior to reuse.

**4.3.4 Accessories.**

**4.3.4.1 Wells.** Wells are the major accessories for bimetallic thermometers. Where pressure, corrosion, or erosion indicate the need for greater protection of the bimetallic element than offered by the bulb, wells should be used. For a general discussion of wells, refer to Section 3.4.1.

**4.3.5 Application and Installation.**

**4.3.5.1 Sources of Error.** Sufficient bulb immersion must be provided to assure that heat conduction along the bulb does not result in an erroneous temperature indication. The required immersion for accurate readings will vary somewhat with the range of the instrument, the bulb material, and the type. Generally speaking, a minimum immersion of 6 cm in liquids and 10 cm in gases is recommended. There is no ambient temperature correction, as such, applicable in the use of bimetallic thermometers.

**4.3.5.2 Essential Considerations.** When using a bimetallic thermometer, the following must be observed.

(1) Decide where to place the bulb of the thermometer considering the following. Does the location selected minimize the shock and vibration to which the instrument is subjected, realizing that pulsation of the fluid on the stem may be as detrimental as motion of the entire unit?

(2) Install the thermometer properly, avoiding the following: (a) parallax in reading; and (b) inadequate illumination.

(3) Do not use the thermometer if the following is true: (a) there is any indication of damage to instrument; or (b) the pointer does not move freely but jumps from point to point with changes in temperature.

(4) The thermometer should be tapped lightly before taking any reading when maximum accuracy is desired.

**4.3.5.3 Treatment of Data.** The observed temperature readings should be corrected to instrument errors using the calibration correction values. Corrections at temperatures other than standardization temperatures should be determined by linear interpolation. Do not apply freezing point or other single point corrections to all points on the scale.

**4.3.6 Advantages and Disadvantages.**

**4.3.6.1 Advantages.**

- (1) Easily read
- (2) No ambient temperature correction
- (3) Protective shell will normally withstand external pressure of up to  $14 \times 10^6$  Pa (2000 lb/in<sup>2</sup>) and is suitable for direct immersion in most fluids

(4) Low maintenance

(5) Liquids and gases are not required in the sensing elements

(6) Low cost

**4.3.6.2 Disadvantages.**

(1) Damage due to shock or vibration may not be evident

(2) In the event of excessive pointer vibrations, the thermometer is difficult to read

**4.4 Thermocouple Thermometers.**

**4.4.1 Principles of Operation.**

**4.4.1.1 Thermoelectric Phenomena.**

When two or more dissimilar metals are connected to form a closed electrical circuit in a region where temperature gradients exist, in general, a net EMF exists in the circuit. If the conductors are homogeneous, the magnitude of the EMF is related only to the temperatures of the junctions between unlike materials and is unaffected by any temperature gradients (transient or steady state) existing in the conductors if these do not alter the junction temperatures.

In the ideal case of a circuit consisting of only two dissimilar metals with the temperature at one junction known, the EMF developed in the circuit may be used as a measure of the temperature of the second junction. This is the basic principle of thermocouple thermometry. In practice, connection of the EMF-measuring device into the circuit results in the introduction of several additional different conducting materials (leads, switch contacts, resistors, etc) and, of course, addi-

tional junctions. If no temperature gradients exist in or between these added elements, the EMF produced is the same as if they did not exist. It is essential, however, to recognize that in addition to the measuring junction there are always at least two other junctions that must be considered. Meaningful measurements are possible only if the temperatures of these junctions are under control.

**4.4.1.2 Thermocouple Tables.** Fig 20 shows several examples of the temperature-EMF relationships for different thermoelements that exist in the ideal case of a circuit consisting of two dissimilar metals and involving two junctions only, one of which is maintained at 0°C. Since the relationships are not linear, a specification of slope is useful only as a measure of sensitivity. The data shown in the figure when presented in tabular form are referred to as thermocouple tables. The tables are usable directly (or where the accuracy sought requires it, with the application of corrections determined for the particular thermocouple in use) only when the reference junction is at 0°C. If the reference temperature differs from 0°C, the tabulated value of EMF corresponding to the reference temperature must be added to the measured EMF to obtain the EMF entry point in the table from which the temperature may be read. This is illustrated in Fig 21.

**4.4.1.3 Thermocouple Circuits.** In principle, the approximation to the ideal is the case where the entire EMF-measuring circuit is of the same material as that used for one of the thermoelements. A close approximation to this situation is illustrated in Fig 22(A) where it is assumed the materials used in the terminals of the EMF-measuring device have negligible thermoelectromotive forces against copper and that the entire device is at a uniform temperature.

A more generally applicable circuit is that of Fig 22(B). In this circuit the two junctions of the thermoelements with the copper lead wires must be maintained at the same "reference" temperature.

Where the accuracy requirements permit, the circuit of Fig 22(C) finds extensive use. The terminals of the EMF-measuring equipment together become the reference junction and their common temperature, the reference temperature.

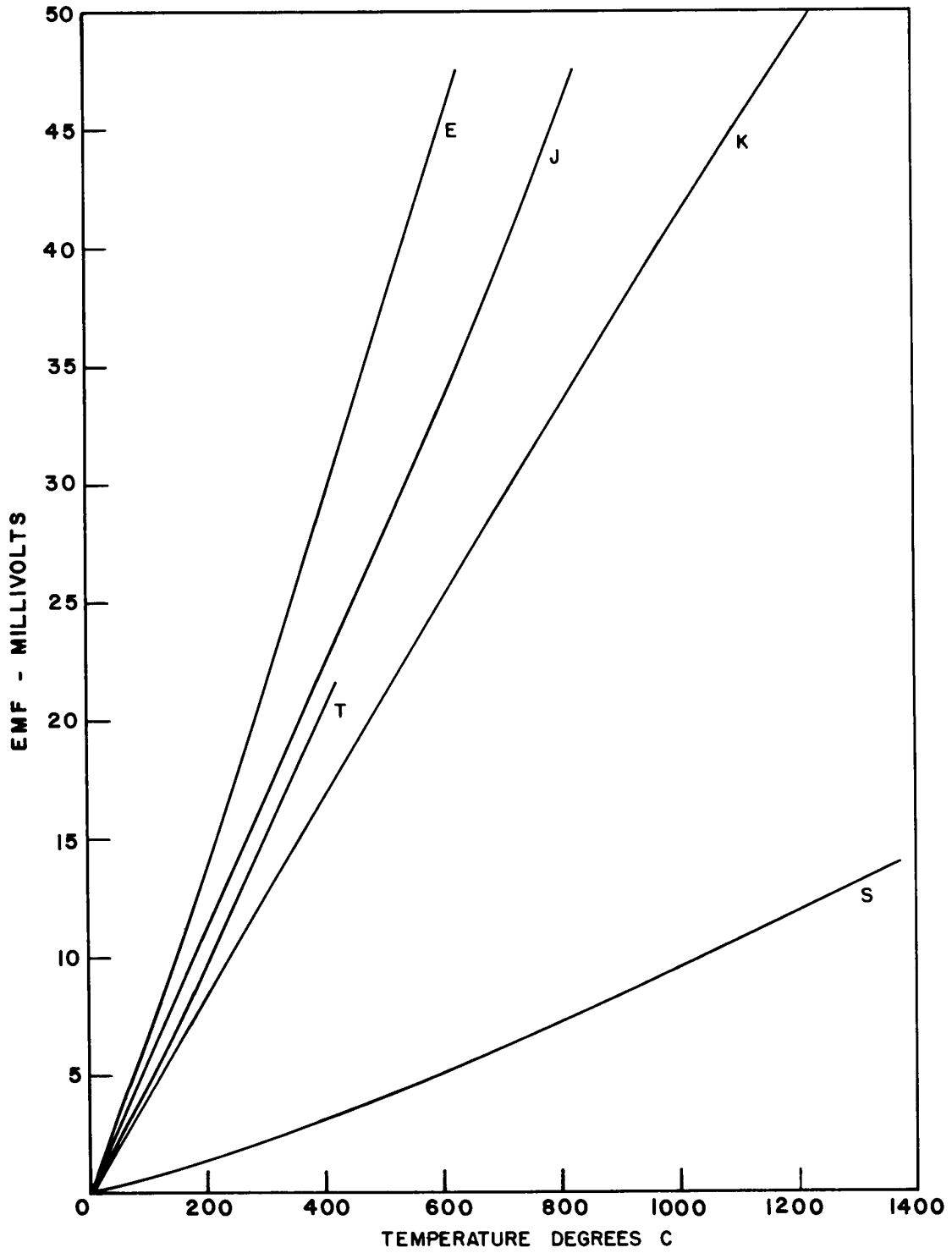

Fig 20  
Thermocouple EMF Versus Temperature for Various Thermocouple Materials  
(Reference Temperature = 0°C)

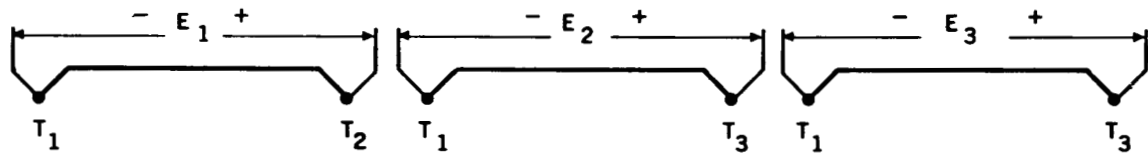
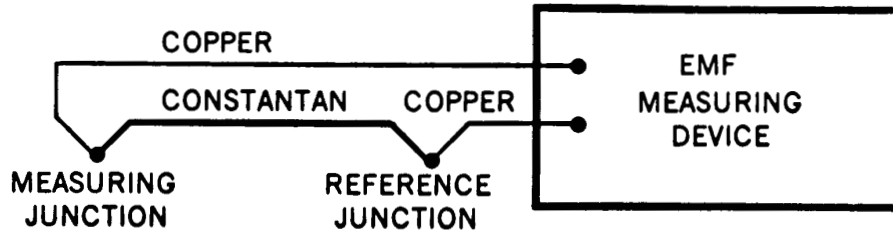
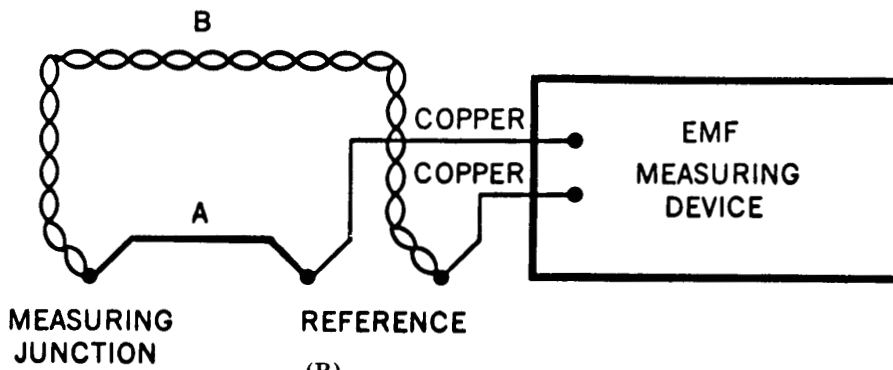

Fig 21  
Thermocouple EMF—Temperature Relations



(A)



(B)

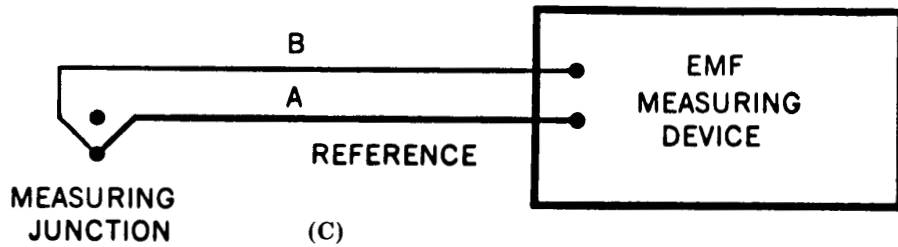

(C)

Fig 22  
Thermocouple Circuits

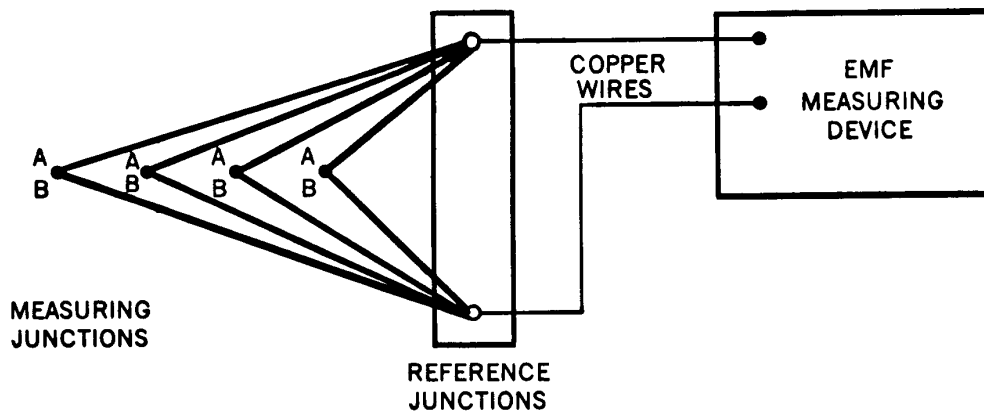

Fig 23  
Thermocouples Connected in Parallel

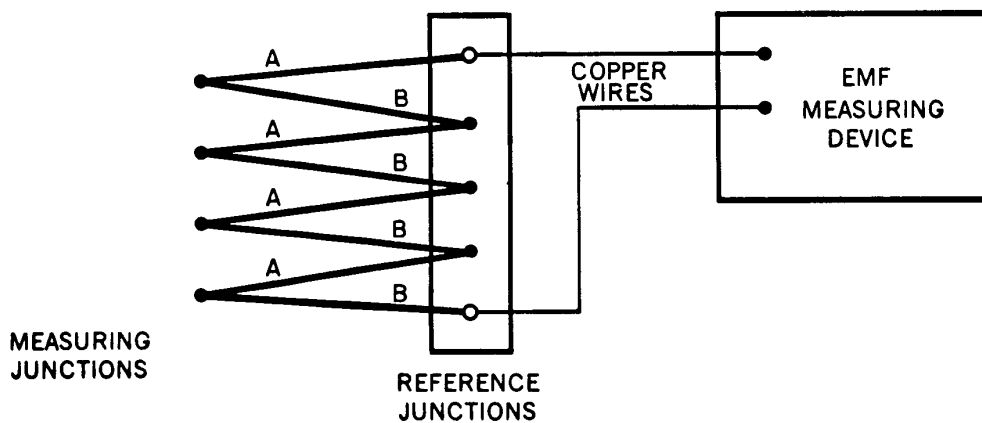

Fig 24  
Thermocouples Connected in Series

4.4.1.3.1 *Thermocouples in Parallel.* A parallel connection of measuring junctions provides a means of averaging the individual temperatures of the several junctions. Unless calibration data show a linear relation between EMF and temperature, for the range of temperatures attained by the measuring junctions, a correct average is not obtained. It is essential that no conducting path, other than that provided by the thermocouple wires, join any two of the junctions. See Fig 23.

In general, a true average temperature indication results only if the paralleled branches are all of equal resistance. If one of the branches becomes open-circuited, temperature indications are still obtained, but they may be seriously in error. Not only is one contribution to the intended average eliminated,

but, if the indicator is a millivoltmeter, its reading is affected by the altered circuit resistance.

4.4.1.3.2 *Thermocouples in Series.* Where thermocouples are connected in series, the measured EMF is the sum of the EMF of the couples. Subject to the same restrictions (except for equal resistance) as for the parallel connection, the series connection also provides a means of averaging the individual temperatures of the measuring junctions. More commonly, however, with the series connection, the measuring junctions are intimately grouped together and the combination, then known as a thermopile, is used as if it were a single thermocouple to increase the sensitivity in the measurement of small temperature differences. See Fig 24.

**4.4.1.4 Reference-Junction Compensation.** As previously indicated, it is necessary to allow for the EMF generated at the reference junction if it is not maintained at 0°C by adding that value of EMF to the measured value. It is possible to accomplish this addition semiautomatically with an electrical compensating network wherein an IR drop is introduced into the measuring circuit of the same magnitude as the EMF produced by the thermocouple at the reference-junction temperature. Such reference-junction compensation is frequently incorporated into so-called thermocouple potentiometers (see Section 4.4.4).

**4.4.2 Classification.** Thermocouple materials are available for use within the approximate limits of -180 to +1750°C. Of the vast number of possible combinations of metals and alloys, only a limited number are in actual use in thermocouple thermometry. These few have been chosen on the basis of such factors as mechanical and chemical properties, melting point, thermoelectric properties, reproducibility, and cost. No single thermocouple meets all requirements, but each possesses characteristics desirable for selected applications.

#### 4.4.2.1 Noble Metals.

**4.4.2.1.1 Platinum Versus Platinum-10 Percent Rhodium Thermocouple (Type S).** This is the instrument used for defining the IPTS-68 from 630.74 to 1064.43°C and is characterized by a high degree of chemical inertness and stability at high temperatures in oxidizing atmospheres. Both thermoelement materials are ductile and can be drawn into fine wires. This thermocouple is widely used in industrial laboratories as a standard for the calibration of base-metal thermocouples and other temperature-sensing instruments. Platinum versus platinum-10 percent rhodium thermocouples as procured from a reputable source will match the standard reference table to ± 0.5 percent of the measured EMF.

**4.4.2.1.2 Platinum Versus Platinum-13 Percent Rhodium Thermocouple (Type R).** This instrument is similar in general characteristics to the platinum versus platinum-10 percent rhodium type. It produces a slightly greater EMF for a given temperature.

#### 4.4.2.2 Base Metals.

**4.4.2.2.1 Copper-Constantan (Type T).** Constantan is the trade name for an alloy of approximately 55 percent copper, 45 percent nickel. The copper-constantan thermocouple is widely used in industrial and laboratory applications over the temperature range -180 to 370°C.

**4.4.2.2.2 Iron-Constantan (Type J).** This thermocouple is probably the most widely used of all thermocouples in industrial thermometry. It is generally limited to the temperature range -130 to 760°C but may be used up to 980°C at a sacrifice of life. For the higher temperatures, wire sizes AWG 8 (3.264 mm diameter) or larger are generally employed. For temperatures up to 760°C, iron-constantan thermocouples show good calibration stability in nonoxidizing atmospheres.

**4.4.2.2.3 Chromel-Alumel (Type K).** Chromel P is an alloy of approximately 90 percent nickel, 10 percent chromium. Alumel has a composition of about 94 percent nickel, 3 percent manganese, 2 percent aluminum, 1 percent silicon. This thermocouple, usable over the temperature range -130 to 1260°C and higher for short time intervals, is more resistant to oxidation than any other base-metal combination. It must, however, be protected against reducing atmospheres. Alternate oxidizing and reducing atmospheres are particularly destructive. Both thermoelements are mechanically strong and are often directly exposed to the temperature environment.

**4.4.2.2.4 Chromel-Constantan (Type E).** This combination of thermoelements develops the highest thermoelectric output of any of the conventional thermocouples, namely, about 61 μV/°C at normal ambient temperature and increasing to about 81 μV/°C at 540°C. This high output has led to the use of chromel-constantan elements as sensors in thermopiles for radiation detection and in differential thermocouple systems. The thermocouple has also found general application for temperature measurements up to about 760°C. It is characterized by a high degree of calibration stability when used at temperatures not exceeding 540°C.

#### 4.4.3 Characteristics.

**4.4.3.1 Range.** In addition to the general range limitations indicated in Section 4.4.2,

**Table 6**  
**Recommended Upper Temperature Limits for a Thermocouple in a Protection Tube**

Materials	Temperature in Degrees Celsius for Wire Size (AWG)				
	8	14	20	24	28
Copper—Constantan (T)	—	370	260	205	205
Iron—Constantan (J)	760	595	480	370	370
Chromel—Alumel (K)	1260	1095	980	870	870
Chromel—Constantan (E)	870	650	540	430	430
Pt 13% Rh—Pt (R)	—	—	—	1480	—
Pt 10% Rh—Pt (S)	—	—	—	1480	—

upper temperature limitations related to the wire size are imposed by ANSI C96.1-1964 (R1969), as indicated in Table 6.

**4.4.3.2 Sensitivity.** The sensitivity of a thermocouple, that is,  $dE/dT$ , varies somewhat with temperature. Table 7 lists the average thermoelectric power for the conventional thermocouples.

**4.4.3.3 Response Time.** The response time of a thermocouple depends on the modes of heat transfer between the junction and its surroundings, as well as the mass and geometry of the junction itself. Using very fine AWG 28 or 30 (0.3211 or 0.2546 mm diameter) thermocouple wires, response times between 10 and 50 ms for exposed couples and of the order of 250 ms for sheathed couples have been measured using boiling water or other stirred or flowing liquids.

**4.4.3.4 Accuracy.** In evaluating the accuracy of a temperature measurement using a

**Table 7**  
**Average Thermoelectric Power for Conventional Thermocouples**

Thermocouple	Average $dE/dT$ , Microvolts per Degree Celsius for Range Specified
Copper—Constantan (T)	50.4 (0—340 °C)
Iron—Constantan (J)	57.6 (0—760 °C)
Chromel—Alumel (K)	41.4 (0—1200 °C)
Platinum—Platinum 10% Rhodium (S)	11.3 (540—1450 °C)
Chromel—Constantan (E)	75.6 (0—760 °C)

thermocouple thermometer, uncertainties in the measurement of the EMF and of the actual temperature of the reference junction must be considered as well as errors resulting from inhomogenities in the thermocouple wire and lack of exact correspondence between the true EMF-temperature relation for the particular couple to be used and the tabulated values for that general type.

The limits of error shown in Table 8 [adapted from Table VIII of ANSI C96.1-1964 (R1969)] may be used as a guide. Care must be exercised in selecting a temperature range, a material, and the standard or special grade of material for the required limits of error. The limits of error may be further reduced by a calibration through the expected range of the measurement.

**4.4.4 Instrumentation.**

**4.4.4.1 Measurement of Thermocouple EMF.** For the materials and the temperature

**Table 8**  
**Limits of Error for Conventional Thermocouples**

Thermocouple Type	Range (°C)	Limits of Error*	
		Standard	Special
Copper—Constantan (T)	—60 to +90	±3/4 °C	±3/8 °C
	+90 to +370	±3/4%	±3/8%
Iron—Constantan (J)	0 to 280	±2 °C	±1 °C
	280 to 760	±3/4%	±3/8%
Chromel—Alumel (K)	0 to 280	±2 °C	±1 °C
	280 to 1260	±3/4%	±3/8%
Chromel—Constantan (E)	0 to 320	±1 1/2 °C	±1 1/4 °C
	320 to 870	±1/2%	±3/8 °C
Platinum—Platinum 10% Rhodium (R)	0 to 540	±1 1/4 °C	±1/4 °C
	540 to 1480	±1/4 °C	±1/4 °C

\*Based on a reference-junction temperature of 0°C.

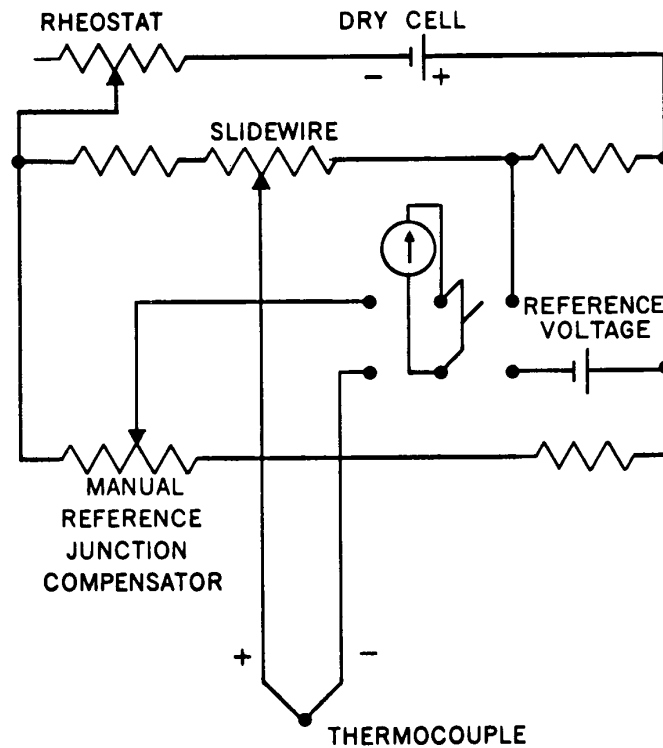

Fig 25

## Thermocouple—Potentiometer Circuit with Manual Reference-Junction Compensator

ranges under consideration, the net EMF has a value of  $40$  to  $80 \mu\text{V}/^\circ\text{C}$  of temperature difference between the measuring junction and the reference junction. Measurement is accomplished either by means of a millivoltmeter or a manually or self-balanced potentiometer.

The simple d'Arsonval-movement millivoltmeter responds to current supplied by the source of EMF to which it is connected. The response can be used as a reliable measure of that EMF only if the resistance of the circuit external to the millivoltmeter lies within prescribed limits. Because some variation of circuit resistance is unavoidable, it is necessary that the millivoltmeter have a high constant internal resistance, usually of several hundred ohms, and therefore that it have a high current sensitivity.

Electronic millivoltmeters having inherently high input impedances do not impose such restrictions on circuit resistance.

Except for minor secondary effects on damping and on sensitivity, the indication of

a potentiometer is not affected by circuit resistance. Manually operated potentiometers afford the highest attainable accuracy in the measurement of EMF. Self-balancing potentiometers give a continuous indication without requiring frequent attention and therefore are generally used where a recording instrument is desired.

**4.4.4.2 Reference-Junction Compensation.** A manually adjusted compensator may be employed to take into account the reference junction EMF as discussed in Section 4.4.1.4. It usually takes the form of an adjustable voltage divider which permits the insertion into the thermocouple circuit of an EMF equal to that of the reference junction relative to a measuring junction at  $0^\circ\text{C}$ . This method requires continual monitoring of the reference-junction temperature by means of a thermometer. If designed for a particular standardized couple, the scale of the manually operated compensator may be graduated directly in terms of reference-junction temperature.

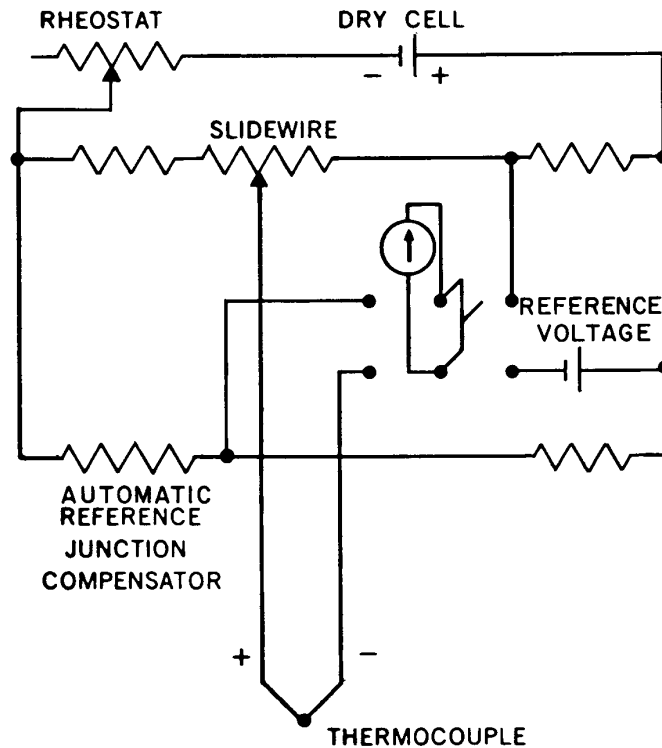

Fig 26

#### Thermocouple—Potentiometer Circuit with Automatic Reference-Junction Compensator

This method, as applied to the potentiometer indicator, is illustrated in Fig 25. If the entire potentiometer is at uniform temperature and the thermocouple wires terminate at the potentiometer binding posts, the reference junction is formed at these posts. By the principles stated in Section 4.4.1.1, the isothermal circuit within the potentiometer produces no net thermal EMF; therefore, so far as such EMF are concerned, there is no distinction between the two binding posts. But if there is a temperature difference between the posts, the circuit contains more than two effective thermojunctions. None of them is properly designated as the reference junction, and accuracy of measurement is impaired.

Automatic compensation may be introduced electrically by inserting into the thermocouple circuit a voltage of a magnitude determined by a temperature-sensitive resistor maintained at the temperature of the reference junction. This resistor may be included in an arm of a split-circuit potentiometer, as shown in Fig 26, or it may be in a separate

bridge circuit inserted in series with the measuring instrument as shown in Fig 27.

Automatic compensation is mechanically applied to millivoltmeters by means of a bimetallic temperature-sensitive element that adjusts the position of the scale or, preferably, that moves one end of a control spring attached to the moving system. In this arrangement also it is necessary that the reference junction be located at or within the millivoltmeter.

**4.4.4.3 Circuits and Switches for Multiple Couples.** If each of a number of measuring junctions is to be connected in succession to a single indicator or recorder, a suitable selector switch must be provided. It is desirable that the switch be double pole, in order that couples not in use may be completely disconnected; that it be constructed of the same material as the wires which connect to it, in order to avoid all the "parasitic" thermal EMF; and that only one reference junction be required. The basic circuit, Fig 28, provides most of these features.

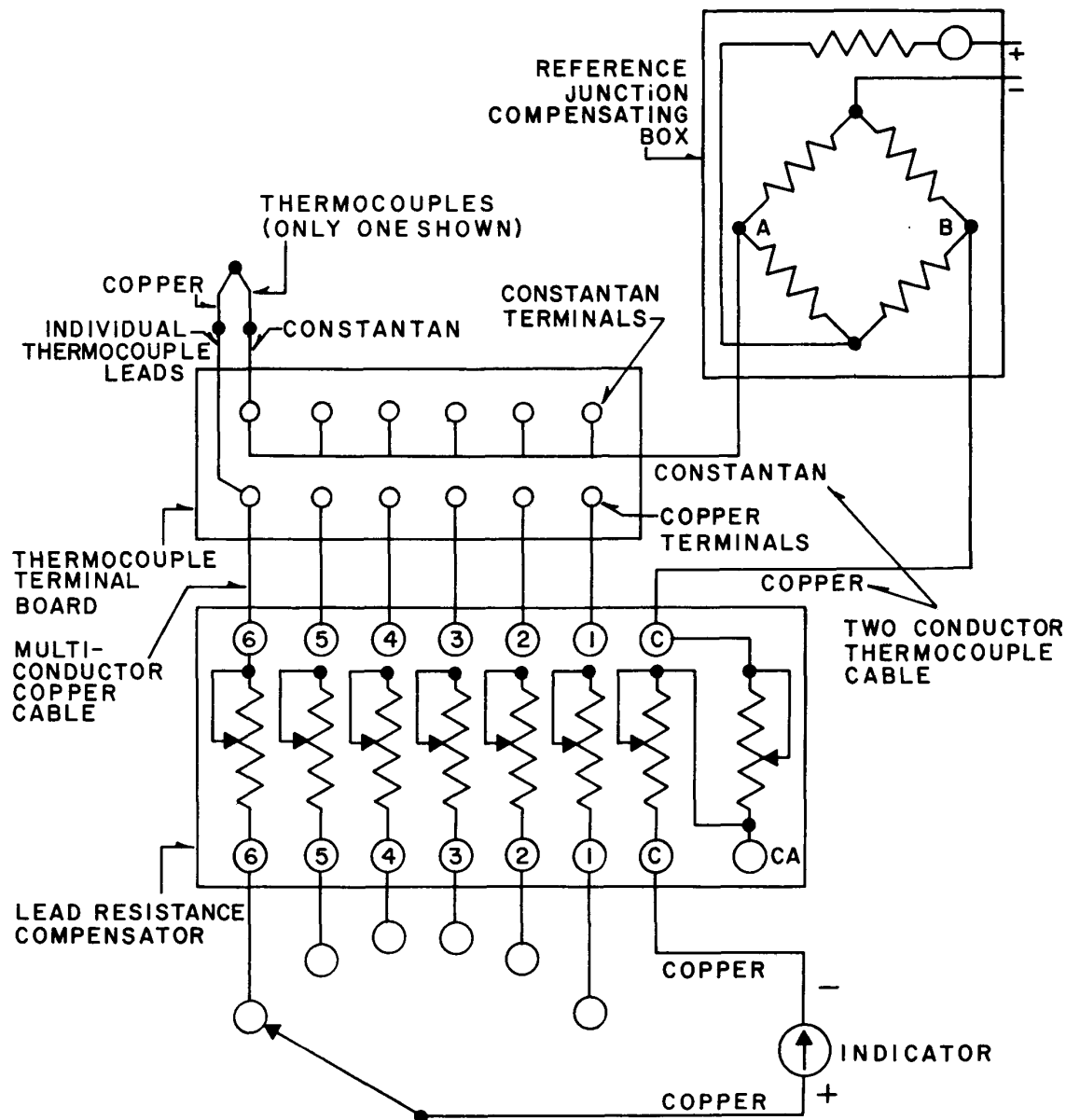

Fig 27  
Circuit for Multiple Thermocouples Using a Single-Pole Selector Switch

The junction box should be so designed and constructed as to assure that all junctions within it shall be at the same temperature.

The double-pole selector switch is essential if any of the couples are electrically connected by means of the substances to which they are applied. If there is no possibility of such interconnection, a single-pole selector switch,

wired in accordance with Fig 27, is satisfactory. The switch and all conductors leading to it should be made of copper.

All terminals, junction connectors, and switch parts should be massive and be capable of maintaining good contact between areas of ample size. These parts must permit low constant electric resistance of circuits connected

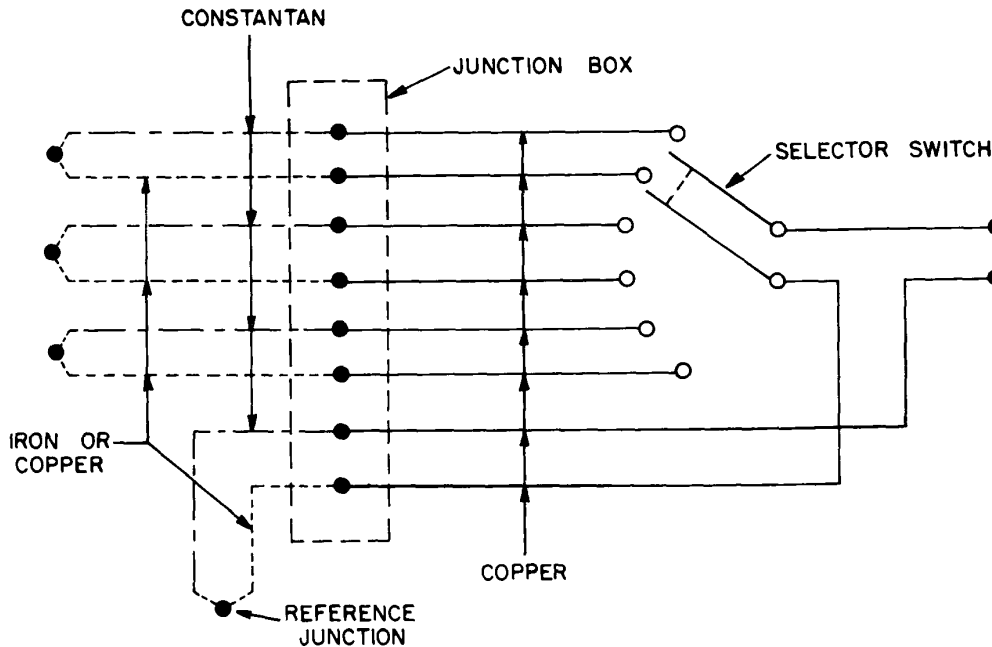

Fig 28  
Elementary Circuit for Multiple Thermocouples

to millivoltmeter indicators, and throughout all pieces of nonhomogeneous metal that are in the thermocouple circuit they must provide good thermal conduction.

Such circuit components as resistors, the springs and coils of instruments, and binding posts, are usually made of metals dissimilar to those which are adjacent in the circuit. Local conditions often determine whether or not such components are subject to appreciable temperature gradients. Each thermocouple circuit should therefore be analyzed carefully in order (1) to insure that it does not contain more than two "active" thermojunctions, and (2) to determine the physical location of the reference junction.

If the indicator is a millivoltmeter, individual measuring-couple circuits must be adjusted to equality of resistance, generally by the use of adjustable resistors located in an isothermal box, as illustrated in Fig 27.

#### 4.4.5 Accessories.

**4.4.5.1 Thermocouple Extension Wires.** Where the highest accuracy is desired, thermocouples should be long enough to connect directly to the instrument or reference-

junction apparatus. This will eliminate errors that might be introduced by the use of extension wires not having temperature-EMF characteristics identical to those of the thermocouple. Where this is not feasible, extension wires from the thermocouple reference temperature junction may be used. For base-metal thermocouple installations, the extension wires are either the same or nominally the same as the thermocouple materials. Extension wires must have the equivalent EMF-temperature relation over the temperature range to be encountered in service.

Because of the high cost of platinum and platinum-rhodium alloys, substitute materials are generally used as extension wires for thermocouples made from these metals. A specially matched pair of conductors, consisting of a copper wire and a nickel-copper alloy wire, have found general use as extension wires for the platinum versus platinum-rhodium thermocouple over the temperature range 0 to 200°C. The copper wire is joined to the platinum-rhodium thermoelement and the copper-nickel alloy wire to the platinum thermoelement. These wires do not

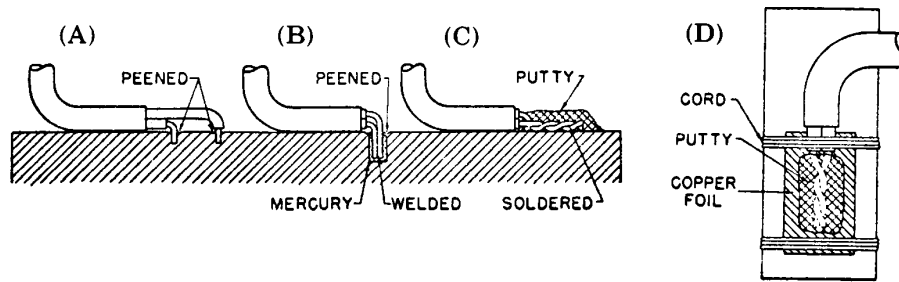

Fig 29  
Methods of Applying Thermocouples to Solids

match the individual thermoelements, but when used together they compensate reasonably well over the range specified above. It is important that the junctions of the extension wires and the thermoelements be at the same temperature.

#### 4.4.6 Application and Installation.

**4.4.6.1 General.** The thermocouple junction, compared to other temperature-sensitive elements, has small surface area with resultant low thermal conductance between the junction and the surroundings. The thermocouple wires may afford a path of comparatively high thermal conductance to regions of quite different temperature. The thermal conductance per unit length of a pair of AWG 30 (0.2546 mm diameter) copper-constantan wires is about equal to that of a glass thermometer stem 6 mm in diameter. To avoid serious inaccuracy, it frequently is advisable to enlarge the effective area of the junction by soldering or welding the junction to a thin metal plate and to lead very small wires away from the junction along a route that for the first few centimeters has a minimum temperature gradient. Such a procedure results, of course, in an increase in response time.

The copper-constantan (Type T) thermocouple is widely used for accurate work at moderate temperatures. However, the high thermal conductivity of the copper leg can lead to appreciable errors in situations where the heat loss from the wires emerging from the environment of the temperature being measured cannot be minimized. In such cases a Type E thermocouple is much preferable since the thermal conductivity of its positive leg is less than one-tenth that of copper. Thermal

conductivities of Type J and K thermocouple wires are also relatively low compared to copper.

**4.4.6.2 Application of Thermocouples to Solids.** The best thermal contact to metallic solids is made by soldering the junction to the metal or by peening the thermocouple wires into shallow close-fitting holes drilled into the metal, as in Fig 29(A). Peening alone may not permanently afford low enough electric resistance for the use of a millivoltmeter indicator.

For temporary or quick attachment, for nonmetallic solids, or for installations that require insulation of the thermocouple circuit, the junction may be soldered to a thin copper plate, which is securely tied to the solid, with a thin sheet of mica interposed if electrical insulation is necessary. Fig 29(B), (C), and (D) illustrates application methods analogous to those recommended for mercury-in-glass thermometers. (See also Section 3.5.)

**4.4.6.3 Application of Thermocouples to Fluids.** Suitable thermometer wells must be interposed between thermocouples and any fluids that can react chemically with the thermocouple metals. Otherwise, corrosion may shorten the life of the couples and alter the resistance of the circuit, while contamination and electrolytic EMF may directly produce error. In general, insulating oils and uncontaminated air are the only commonly encountered fluids to which unprotected thermocouples may safely be exposed.

**4.4.6.4 Contact Thermocouples.** A thermocouple that can be applied quickly to a metallic solid is made by terminating the two dissimilar conductors in parallel pointed rods whose compositions correspond, respectively,

to those of the conductors. In the use of this thermocouple, these probes are pressed firmly against the metal whose temperature is to be measured, so that the metal forms part of the thermocouple circuit. This principle is similar to that illustrated in Fig 29(A).

The metallic-probe thermocouple practically eliminates time lag between the instant of applying the thermometer and the taking of a reading. It can be applied to a commutator, for example, immediately after shutdown to obtain a reading that requires no allowance for cooling.

**4.4.6.5 Construction of Thermocouple Junctions.** The method employed for making the junction between the thermoelements has no influence on the EMF developed, providing good electrical contact is attained. The most widely used method for making the junction is **autogenous welding**, in which the thermoelements are fused together by a torch or by electrical means without using any other material to form the junction. The noble metals should be welded without using a flux. For torch-welding base metals it is advantageous to use a flux to minimize oxidation. Care should be exercised in the application of heat to the ends of the thermoelements to avoid overheating. All traces of flux should be removed after the welding process.

The thermocouple junction may be formed by soldering or brazing with a material that is compatible with the thermoelements at the temperatures to be encountered in service. Care should be taken to prevent the solder or brazing material from running back from the junction. All traces of flux should be removed.

In addition to providing reliable electric conduction, solder may be necessary to improve thermal conduction and to provide means of attachment, but neither the quantity applied nor the distance that the solder extends along the conductor should be excessive.

The mechanical strength of the junction may be increased by twisting the wires together for a few turns at the junction end. The twist should be omitted whenever the thermocouple is to be used where a temperature gradient exists at the junction. The temperature measured is that at the first point of the electrical contact proceeding from the reference junction to the measuring junction.

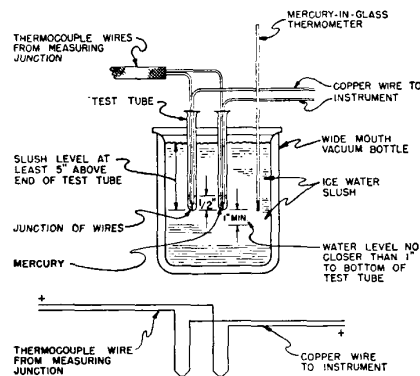

Fig 30

#### Thermocouple Reference-Junction Ice Bath

**4.4.6.6 Insulation.** The electrical insulation between the conductors must extend toward the junction as far as there is possibility of temperature gradient along the conductors. High-temperature thermocouples may be insulated by materials such as porcelain, alumina, and magnesia applied as beads, tubes, or as powder encased in metallic sheaths. For lower temperature applications, insulation may be of asbestos (good to 550°C), fiberglass (good to 500°C), plastic, or enamels.

**4.4.6.7 Reference Junction.** For high-accuracy measurements, a carefully prepared and properly maintained ice bath is commonly used to establish the temperature of the reference junction. Fig 30 shows one satisfactory arrangement. Another consists in soldering the junction to the inside of a short copper tube which is closed at one end and which has copper fins soldered to its outer surface. A rubber tube, fitting tightly over the open end of the copper tube, contains the wires and excludes excessive moisture from them, at the same time conducting a minimum of heat to the copper. The large surface area of the latter assures good thermal contact between the junction and the ice. The entire assembly can conveniently be contained in a wide-mouthed thermos flask.

Constructing a reference junction by merely burying a few centimeters of the bare junction and its wires in cracked ice may result in errors of several degrees.

For intermediate to relatively high-accuracy measurements, the reference junctions may be mounted in a heavy copper block, the temperature of which is determined by means

of another thermometer, for example, a liquid-in-glass or resistance thermometer.

#### 4.4.6.8 Sources of Error.

**4.4.6.8.1 Temperature Gradients.** Ideally, a small-size thermocouple-measuring junction suitably embedded in a solid or immersed in a liquid will attain equality in temperature with the substance and will, therefore, indicate the true temperature of the solid or liquid to within the calibration accuracy of the instrument. However, in many applications this may not be the case. If under steady conditions there is a net exchange of heat between the thermocouple junction and the substance, then a difference in temperature will exist between the two. The magnitude of this difference in temperature depends upon the rate of heat transfer and the thermal resistance between the junction and the substance. As an illustration, suppose it is desired to measure the temperature of a metal plate which is heated from within by some means. The bare thermocouple measuring junction is brought into contact with the metal plate. The junction will receive some heat from the plate by thermal conduction and probably a smaller amount by radiation and convection. The junction will lose heat by conduction along the thermocouple wires, and by convection, conduction, and radiation to the surroundings. Obviously the junction will be at a lower temperature than the plate. This difference in temperature can be reduced by the following:

- (1) Improving the thermal contact by the following:
  - (a) Flattening the junction to obtain a larger area of contact
  - (b) Soldering, brazing, or welding the junction to the plate
- (2) Reducing the heat loss from the junction by the following:
  - (a) Using thermocouple wire of the smallest practical diameter
  - (b) Keeping the wires close to the plate for some distance so as to reduce the temperature gradient in the wires near the junction
  - (c) Raising the temperature of the space surrounding the junction by use of insulation or an auxiliary source of heat

**4.4.6.8.2 Electrical Leakage.** The elements of a thermocouple must be electrically insulated from each other, from ground, and from conductors on which they may be mounted, except at the measuring junction. When a thermocouple is mounted along a conductor, such as a pipe or a metal structure, special care should be exercised to insure good electrical insulation between the thermocouple wires and the conductor to prevent stray currents in the conductor from entering the thermocouple circuit and vitiating the readings.

**4.4.6.8.3 Instability.** Thermocouple sensors are subject to some shifting of the EMF versus temperature characteristic with time and temperature cycles. The instability increases with age and depends upon the temperature levels being monitored, materials in the thermocouple, and contamination.

Thermocouple EMF-measuring devices are susceptible to error due to electrical component resistance changes with time, reference voltage changes in batteries or electronic reference supplies, mechanical friction, and servoamplifier gain reductions which allow excessive error signals in the recorder position-servo loop.

These errors may be discovered and corrected by routine calibration of the system or components.

**4.4.6.8.4 Electrical Noise.** Extraneous EMF can be induced in the thermocouple circuit if it is allowed to form a coupling loop with magnetic fields. The use of twisted and shielded extension and thermocouple wire placed in separate wireways will generally reduce the noise voltages to levels which are not detectable.

Common mode voltages can be generated if the system has more than one connection to ground. This often occurs when grounded junction thermocouples required for fast response are used with a measuring circuit that is grounded. Allowing the shield on extension wire to be grounded in more than one location also provides a circuit for common mode voltages.

#### 4.4.7 Advantages and Disadvantages.

##### 4.4.7.1 Advantages.

- (1) Simple in basic design and operation
- (2) Small in size, flexible, capable of installation in relatively inaccessible spaces

Table 9  
Characteristics of Resistance Thermometers

Characteristic	Platinum Thermometer	Nickel Thermometer	Copper Thermometer	Thermistor
Range*	-260 °C to +500 °C (750 °C)	-75 °C to +150 °C (300 °C)	-75 °C to +150 °C	-80 °C to +270 °C (-300 to +500 °C)
Accuracy				
Industrial	±0.6 °C	±0.3 °C	±0.3 °C	±2 °C
Special	±0.001 °C		±0.1 °C	±0.1 °C
Nominal Resistance				
Customary	25 Ω	100 Ω	10 or 100 Ω	10 to 10 <sup>5</sup> Ω
For special applications	(10 to 1380 Ω)	(50 to 600 Ω)		
Sensitivity	0.1 Ω/°C	0.4 Ω/°C	0.04 Ω/°C	-1% to -8%/°C
Response Time <sup>†</sup>	5 to 15 s	15 to 40 s	15 to 40 s	0.2 to 3 s

\*The ranges of usefulness of most readily available thermometers are as indicated. The figures in parentheses indicate, however, that there are available thermometers which can be used outside those ranges.

<sup>†</sup>In stirred water moving at a rate of 0.3 m/s.

(3) Suitable for remote indication, signal may be used to indicate, record, or control temperature

(4) Primary elements are relatively low in cost

(5) All components of the measuring system are individually replaceable

(6) Suitable for wide range temperature applications

(7) High accuracy attainable

#### 4.4.7.2 Disadvantages.

(1) A relatively small signal output is produced requiring sensitive measuring equipment

(2) Knowledge of or compensation for reference-junction temperature is required

(3) Subject to calibration changes with use

### 4.5 Resistance Thermometers (Resistance Temperature Detectors).

**4.5.1 Principle of Operation.** Resistance thermometry is based on the change in resistivity with temperature in a known and reproducible manner exhibited by most metals and some semiconductors. Thus temperature is determined by measuring the resistance of a calibrated resistor inserted in the medium or at the location where the temperature is to be determined. (See also Section 6.1.)

**4.5.2 Classification and Construction.** Resistance thermometers are usually classified according to the material from which the sensor is constructed.

**4.5.2.1 Platinum Resistance Thermometers.** The platinum resistance thermometer is the instrument used for defining the IPTS-68 from 13.81 K to 630.74 °C.

Platinum is particularly well suited as the resistance material for high-accuracy thermometers for the following reasons: the relation between resistivity and temperature is very simple and holds over a wide temperature range; its resistivity is relatively high; its temperature coefficient of resistivity is satisfactory; it is very stable physically; it is resistant to corrosion; it can be stress relieved by heating to high temperature in air; and it can be drawn to very fine wire sizes.

Since platinum is subject to contamination by reducing atmospheres and metallic vapors, it is usually employed in a sealed area or mounted in a protecting tube. In a typical construction the platinum wire is wound in a double helix on a mica form, and the entire assembly placed in a tube of chemical resistant material<sup>5</sup> and sealed.

**4.5.2.2 Copper Resistance Thermometer.** Copper is also an excellent material for use in resistance thermometry. Its temperature coefficient is slightly greater than that of platinum. It can be secured commercially in a pure state so that an established temperature-resistivity table can be matched without difficulty. The temperature-resistivity curve is nearly linear between -50 °C to +200 °C.

<sup>5</sup>Such as Pyrex.

Therefore, two resistance thermometers can be used for temperature-difference measurements with a compensator being used to match the resistance of the two thermometers. The stability of calibration of copper sensors is excellent. They can be depended upon to maintain their accuracy over long periods of time provided the manufacturer's temperature limitation is not exceeded.

In a common method of construction, the insulated wire is wound bifilar on a metal bobbin. Two leads are attached to one end of the winding and one to the other end to permit compensation for the effect of ambient temperature changes and for temperature gradients in the leads. The bobbin is inserted in a thin-walled metal tube, closed at one end. It must make intimate contact with the inside of the tube so as to obtain a high speed of response. The protecting tube over the sensor is sealed.

Copper resistance sensors intended for insertion in the windings of electrical machinery as embedded detectors are made of grids of copper embedded in flexible plastic strips.

**4.5.2.3 Nickel Resistance Thermometers.** Nickel can be used satisfactorily as a sensor material. Its lower cost as compared with platinum makes it attractive for industrial applications. It is somewhat less stable than either platinum or copper, and its useful upper temperature limit is determined by the insulation on the nickel wire. This is usually enamel, silk, or cotton.

**4.5.2.4 Thermistors.** In general, thermistor sensors are used where sensitivity, speed of response, ruggedness, and small size requirements exceed those obtainable with other types of sensors.

Thermistors, however, have limited use because of their short useful temperature range and noninterchangeability. The high resistance of these sensors minimizes the effect of lead length variations; while the high temperature coefficient of resistance permits the design of circuits having high sensitivities. Thermistors cannot be obtained with a uniformity of resistance at a given temperature to better than about 20 percent, although by selection, resistance matching to about 2 percent can be realized. This lack of interchangeability requires individually calibrated adjustments in original as well as in replacement units.

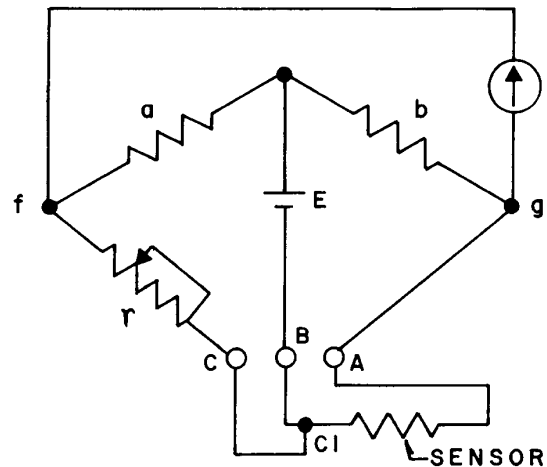

Fig 31  
Elementary Bridge Circuit for  
Resistance Thermometry

The temperature-resistance relation is exponential in nature, and this nonlinearity limits the range of calibrated thermistors to relatively narrow temperature spans.

**4.5.3 Characteristics.** A tabulation of the characteristics of resistance thermometers is given in Table 9.

#### 4.5.4 Instrumentation.

**4.5.4.1 Balanced-Bridge Measurements.** Realizations of the highest accuracy feasible with a precision platinum thermometer require use of bridges specially designed for the purpose. Among those currently in use are Wheatstone bridges of the Mueller type, dc current comparator bridges, and ac Kelvin bridges. (See [4], [64], and [65].)

Fig 31 shows a schematic diagram of a Wheatstone bridge circuit as used for resistance thermometer measurements. Resistors  $a$  and  $b$  are ratio arms of equal resistance; resistor  $r$  is a variable resistor, the value of which can be adjusted to balance the bridge; and resistor  $x$  is the sensor. Three wires  $A$ ,  $B$ , and  $C$  connect the measuring instrument and the sensor. Of these, wires  $A$  and  $C$  should be identical in size, length, and material and should be placed side by side throughout their length so as to be alike in temperature. The  $B$  wire, which is a feeder wire, need not be similar to the others; however, it is common practice to form the three wires into a cable and make them all alike. Wires  $A$  and  $C$  are in the sensor arm  $x$  and the variable resistor arm  $r$ , respec-

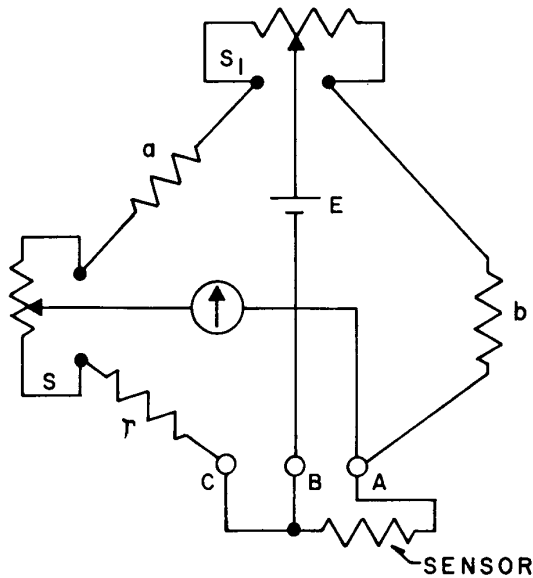

Fig 32  
Bridge Circuit for Avoiding Effects of  
Resistance at Moving Contacts

tively. Their resistances remain equal although their temperature condition may change; and, hence, with a one-to-one bridge ratio, such changes have no effect on the bridge reading. The effect of contact resistance variations as well as those resulting from unequal leads may be reduced by using a sensor of several hundred ohms.

The bridge circuit shown in Fig 32 is used by several manufacturers.  $S$  and  $S_1$  are uniform slide wires of equal length;  $S$  has twice the resistance of  $S_1$ . The contacts of the detector and feeder leads are moved simultaneously and by equal distance along the slide wires to balance the bridge. The variable contacts are thus placed in the feeder and detector circuits where they can have no effect on the balance point of the bridge while a one-to-one bridge ratio is constantly maintained.

Measurements essentially free from errors associated with contact resistances and with variations in lead resistances are accomplished using four-lead thermometers in sophisticated Mueller or current-comparator type bridges.

**4.5.4.2 Deflection-Bridge Instrument.** In the deflection-bridge type of indicator, each of three arms of the bridge circuit is a fixed resistor of low temperature coefficient, and the

fourth arm is the sensor. The unbalanced voltage of the bridge is applied to an off-zero millivoltmeter having a scale marked in degrees. The constant-voltage dc supply required for the circuit is usually obtained from a 115 V ac source by means of a constant-output voltage transformer and a rectifier, both mounted within the indicator case (Fig 33). A battery supply in the order of 20 V may be used if available in place of the transformer and rectifier portion of the circuit.

The sensors are usually located at a considerable distance from the bridge-measuring circuit. Frequently a single measuring circuit is used to measure the resistance of several sensors by suitable switching means. Since the connecting wires form a part of the measuring circuit, certain precautions must be taken. Copper wires of course have a temperature coefficient of the same order of magnitude as that of the sensor used. If the resistance of the leads is appreciable in comparison with the sensor, it may introduce large and uncertain errors into the temperature measurement.

It is necessary, therefore, that the resistance of the leads be maintained within certain limits and that this resistance be incorporated in the measuring circuit. As illustrative of the problem, a typical multipoint installation is shown in Fig 34. With a  $10\ \Omega$  copper sensor, typical lead resistances should be in the order of  $0.02\ \Omega$  for  $L_2$  and branch leads and  $0.3\ \Omega$  for  $L_1$  leads. The resistance values for all  $L_1$  leads must be the same with  $0.02\ \Omega$ . Accommodation for  $L_1$  lead resistances greater than  $0.3\ \Omega$  can be made provided these resistance values are included in the calibration of the measuring circuit.

The switch used for changing measuring points must be of high quality. One having make-before-break wiping contact reduces the transient overloads on the detector and tends to minimize contact resistance variations. The switch must have enough positions to connect the required number of sensors, plus one test position in which a standardizing resistor is introduced, and an "off" position. Contact CSA in Fig 34 is open in the off position and closed in all other positions.

**4.5.4.3 Crossed-Coil Indicator.** Fig 35 shows the schematic diagram for a temperature indicator of the crossed-coil type for operation from an ac source. The transformer and rectifier may be omitted for dc operation.

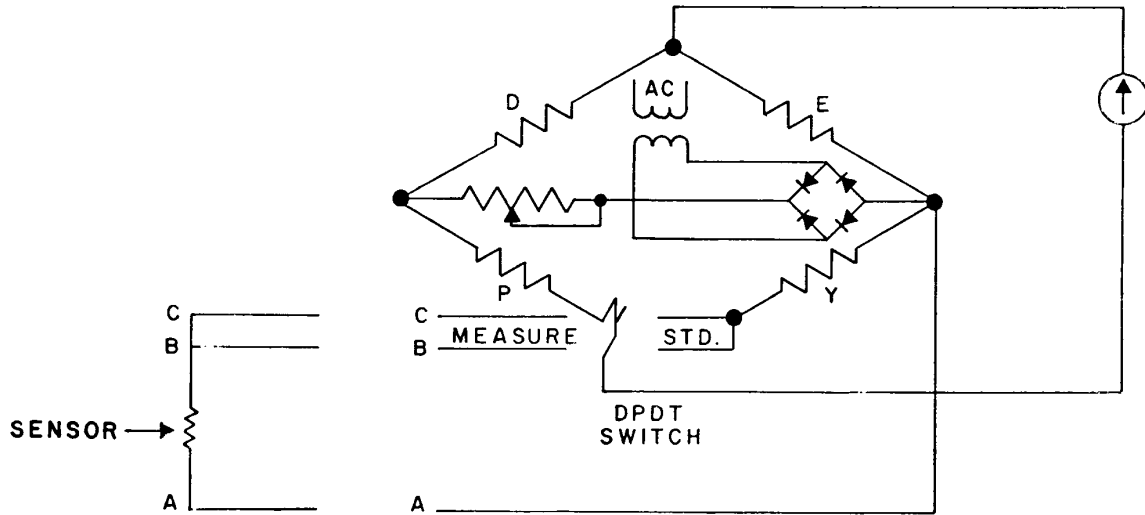

Fig 33  
Deflection Bridge Instrument, AC Supply

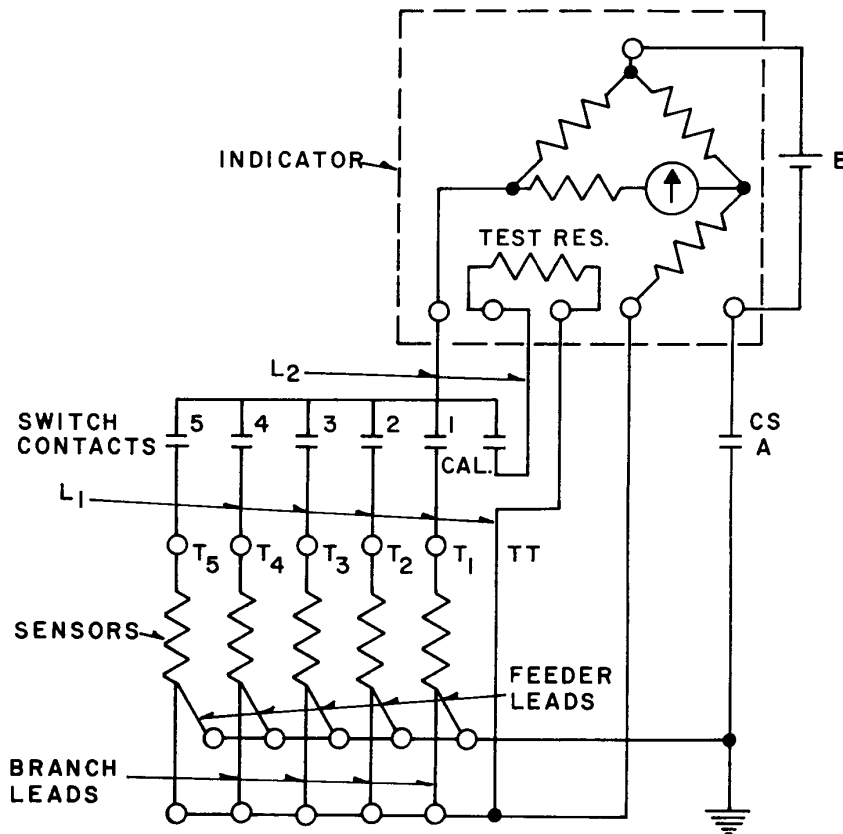

Fig 34  
Typical Multipoint Deflection-Bridge Resistance Thermometer Installation

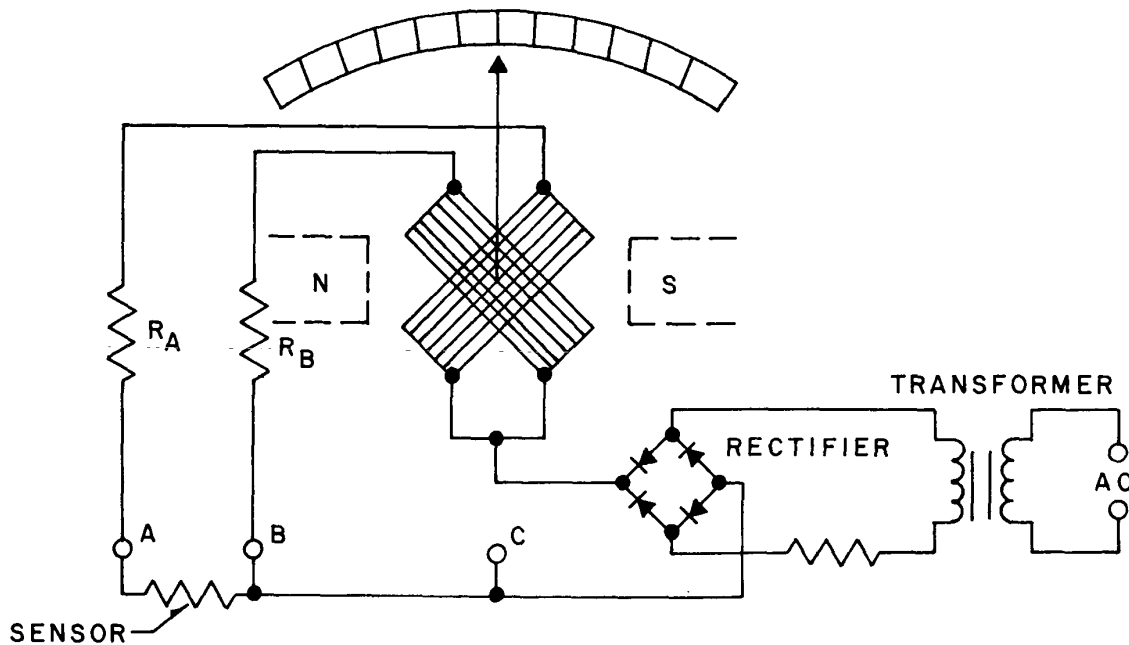

Fig 35  
Crossed-Coil Temperature Indicator Operated from AC Source

A dc supply as specified by the manufacturer should be used in this case. Such a supply is usually in the order of 20 V dc.

$R_A$  and  $R_B$  are low-temperature-coefficient resistors used for adjustment. In this arrangement, a variation of  $\pm 10$  percent in supply voltage has no appreciable effect on the accuracy.

#### 4.5.5 Application and Installation.

**4.5.5.1 Essential Considerations.** Certain precautions must be observed if reliable temperature determinations are to be made with a resistance thermometer. The thermometer coil must be immersed to a depth sufficient to prevent a significant error from transfer of heat along the thermometer leads and protecting tube. A check of the adequacy of the immersion in each uniform constant-temperature bath may be made by varying the depth of immersion of the thermometer and noting whether there is a significant change in resistance. When a measuring current flows in the thermometer, some heating of the resistor results; consequently, where possible the same current should be used in making measurements as was used in the calibration. Sufficient time must be allowed, after the current is turned on, for equilibrium to be established.

The constants of a thermometer may change as a result of changes in the dimensions of the wire, strains in the wire, or the subjection of the thermometer to excessive temperatures. It is particularly important that care be taken to protect the thermometer from small mechanical shocks, each of which strain the wire slightly to produce small changes in the characteristics of the wire in the resistor. If the measured resistance at a reliable fixed point is found to have changed by a significant amount, and the change cannot be attributed to the bridge, recalibration of the thermometer is advisable. (See also Section 3.5.)

In all of the measuring circuits described, it is necessary that the installation instructions of the manufacturer be followed. The connections should be made using copper cable AWG 16 or 18 (1.291 or 1.024 mm diameter) individually insulated with temperature-resistant material. All feeder leads to multiple sensors should be connected together and grounded.

All connections must be well made, soldered where possible when solid wire is used. Terminal lugs should be soldered to the sensor leads and securely clamped by means of terminal studs, washers, and nuts. The contact resist-

ances of transfer switches must be kept low by frequent cleaning followed by the application of a thin film of petroleum jelly.

**4.5.5.2 Sources of Error.** Because of its large sensing area, the resistance thermometer is relatively more sensitive to radiation errors when, for example, it is used to measure the temperature of a gas in a duct or pipe with walls which differ significantly in temperature from that of the gas.

The measuring current in the resistance thermometer will raise its temperature above that of its surroundings. In cases where it is not possible to operate with a test current sufficiently low that this error is negligible, an extrapolation to zero current based on measurements at two current levels is considered good practice.

Induced ac voltages in the thermometer leads may introduce errors. The precautions suggested in Section 4.4.6.8.4 for minimizing the effects of stray fields are equally applicable to measurements with resistance thermometers.

#### **4.5.6 Advantages and Disadvantages.**

##### **4.5.6.1 Advantages.**

- (1) By proper selection, resistance thermometers may be used to cover ranges exceeding  $-260$  to  $+750^{\circ}\text{C}$
- (2) High accuracy
- (3) Excellent stability and reproducibility
- (4) Interchangeability
- (5) Can be matched to close tolerances for temperature-difference measurements

##### **4.5.6.2 Disadvantages.**

- (1) Relatively slow response
- (2) Require careful handling to prevent mechanical damage
- (3) Relatively high cost

## **5. Infrared-Radiation Thermometer Systems**

**5.1 Principles of Operation.** A body which is heated to a temperature higher than its surroundings loses heat energy in one of three ways: conduction, which is the flow of heat through the intervening medium without motion of that medium; convection, which is heat carried by motion of the intervening medium; or by radiation, which is heat energy propagated through the intervening medium

by electromagnetic wave propagation, as is the case with visible light. It can be demonstrated that the rate at which heat energy is radiated from a body depends to some extent on its composition and surface condition but principally on its absolute temperature, the rate being approximately proportional to the fourth power of the temperature. Thus, devices which can be arranged to measure the rate at which they receive electromagnetic radiation from a body may be used as a means of measuring its temperature. Since the spectral distribution of the radiation from a surface does depend to some extent upon the composition and surface conditions as well as upon the absolute temperature, temperature-measuring devices based on this principle are most readily applied in the measurement of temperature differences only. Such devices used with electrical apparatus must be designed to respond to radiation in the infrared region since at the temperatures of interest the spectral distribution of the radiation is such as to concentrate most of the energy there.

**5.2 Classification.** Radiation thermometers of two basic types are of importance in temperature measurements of electrical apparatus. These are the fixed-point and the display or image types.

**5.2.1 Fixed-Point Type.** The fixed-point-type instrument uses an optical system roughly similar to that of a small reflecting telescope to focus the image of a very restricted region onto a thermistor, thermopile, or other type of radiation detector that drives an indicating meter whose deflection is related to the average temperature of the objects in the field of view.

**5.2.1.1 DC Gun Type.** The dc gun-type instrument is the simplest form. The detector output drives a d'Arsonval meter through a dc amplifier.

**5.2.1.2 AC Chopper Type.** The ac or chopper-type instrument uses a shutter mechanism to alternately expose and shield the detector from the incident radiation, thus permitting narrow-bandwidth amplification of the output signal. When equipped with an internal "black-body" reference, this type offers the highest sensitivity, stability, and accuracy available in this general class of infrared temperature measurement systems.

**5.2.2 Image Type.** The image-type instruments produce a visual display of the region under study with either the color or the brightness of the objects within the field of view being a measure of their temperature. Some instruments of this type can be considered as relative temperature indicators only; however, others are provided with a facility for establishing a reference temperature and thereby permit reasonably accurate temperature measurements.

**5.2.2.1 Direct-Image Type.** The direct-image-type instrument, which usually produces a color display, requires that the camera remain motionless for from 5 to 30 s. The instrument transforms the invisible infrared radiation emanating from objects in the field of view into radiation in the visible spectrum, although the transformation is not a direct one with regard to wavelength.

**5.2.2.2 Scanning-Image Type.** The scanning-image-type radiation thermometer produces a black and white image of the field with the brightness of the image of an object being related to the intensity of the radiant energy being emitted by that object. The image is formed on a cathode-ray tube at a rate typically between 1 and 60 frames per second for one class of instruments and with scanning times of 1/2 to 3 min for a class which uses a different type of radiation detector.

### 5.3 Characteristics.

**5.3.1 Range.** The dc gun type has a useful range of from 0 to 100°C above ambient with special models available having ranges as high as 0 to 500°C. The chopper and image types are normally considered useful over the range -50 to +150°C; however, special models are available with upper limits as high as 3000°C.

**5.3.2 Precision.** The gun and direct-image instruments provide measurements with a precision of 1 or 2°C. The scanning-image type is somewhat more sensitive with a precision of 0.2 to 0.5°C being available, depending on the scanning time. The chopper type provides a precision of 0.05°C over most of its range.

**5.3.3 Accuracy.** At present, the infrared-radiation temperature-measuring devices are finding application in the electrical power industry almost solely for locating system components that are operating at above normal

temperatures. Accuracy of temperature measurement is not usually of great interest since the principal concern is with measurements of temperature differences. Accuracies of the order of  $\pm 5^\circ\text{C}$  for the dc gun type,  $\pm 1^\circ\text{C}$  for the image types, and  $0.5^\circ\text{C}$  for the chopper type may be expected in the measurement of temperature differences of  $40^\circ\text{C}$  or larger. For differences of  $10^\circ\text{C}$  or less, the accuracy is somewhat better, approaching the values given above for precision.

**5.3.4 Response.** Response time of the fixed-point-type instrument is basically that of the indicating output meter, that is, of the order of 1 s or less. However, if equipped with a recorder or other suitable readout device, the ac fixed-point instrument may exhibit a response time as low as 0.01 s. The scanning-type instrument may provide an output as frequently as 16 times a second; however, analysis and interpretation of the image, which constitutes the output, to provide quantitative measurements of temperatures to the full accuracy available takes several minutes. The direct-image-type instrument suffers from the same analysis and interpretation delay in addition to the requirement of a 5 s minimum exposure time.

**5.3.5 Mechanical Stability.** Infrared-radiation thermometers are relatively delicate instruments, and while they may be transported and used safely in trucks or airplanes, reasonable precautions against damage from mechanical shock must be taken.

**5.3.6 Temporal Stability.** Infrared-radiation thermometers are essentially self-protecting from overloads; however, except for the chopper type with a built-in black-body reference, temporal drifts in the various components make relatively frequent calibration necessary. With some instruments this is a very simple procedure, accomplished by the user in a matter of a few seconds.

**5.4 Accessories.** Where maximum accuracy is required with the dc gun-type instrument, an auxiliary calibration unit is required. One form that has been used successfully contains two "targets" maintained, by means of thermistors and a differential amplifier heating unit, at temperatures which differ from each other by  $10 \pm 0.5^\circ\text{C}$ .

Sharp-cutoff sunlight filters are available for use with the image-type instruments. These filters attenuate the undesired sunlight sharply while introducing only about 1 dB attenuation of the desired radiation. With some gun-type instruments a similar filter is built in. The scanning-type instrument is frequently used mounted on a slowly moving truck or helicopter in inspecting transmission lines. Fixed-wing aircraft have been used successfully in some such surveys.

## 5.5 Application and Installation.

**5.5.1 Sources of Error.** The fact that the fixed-point-type instrument responds to an average effective temperature of whatever objects are included in its field of view introduces the possibility of serious error. Actually if the object whose temperature is to be measured subtends an angle which is substantially smaller than the viewing angle of the instrument, the object may be lost in the background. Application of multiplier factors given by the manufacturers reduce the errors to an acceptable level if the temperature of the background is ambient; however, if the background is blue sky, for example, only relative readings are meaningful and considerable care must be taken in their interpretation. There exists additionally a "fringe" effect in that a small (perhaps 5 percent) portion of the energy reaching the detector arrives from regions outside the theoretical cone of vision. Infrared reflection from the sun off either the equipment being studied or other equipment in the field of view can introduce errors.

Variations in the emissivity of the surfaces being viewed may introduce errors. Some fixed-point instruments permit adjustment for emissivity (useful when it is known), but with the image-type instrument the emissivity remains a problem which must be taken into account in interpretation and evaluation of the data.

**5.5.2 Essential Considerations.** Environmental factors impose severe limitations on measurements with a sensitive infrared-radiation instrument. Ideal conditions in working with outdoor equipment seem to be either calm overcast days or early morning or evening hours when solar effects are minimum. When measurements are made in the sun, it must be remembered that solar energy, unless

filtered out, reflected into the thermometer may be large compared to that being radiated by the devices being studied. Observations taken from several angles may be helpful in identifying and avoiding errors from reflected sunlight.

In using the fixed-point-type thermometer, the size of the viewing spot must always be kept in mind. In an instrument where the spot is 5 cm per 6 m of distance, that is, 25 cm at 30 m, it is evident that if the backgrounds are significantly different when the instrument is aimed at the object under study and when aimed at the object used for establishing the reference temperature, serious errors may be introduced.

**5.5.3 Treatment of Data.** In general, the data taken with an infrared-radiation thermometer require careful analysis and interpretation. As an aid to reader interpretation, it is often found desirable to make ordinary photographic records of the field of view from positions where measurements are taken.

## 5.6 Advantages and Disadvantages.

### 5.6.1 Advantages.

(1) A significant advantage is that of remote (up to 30 m for the gun type) indication of temperature without the necessity for direct connection to the object under observation

(2) The image-type instruments provide relative temperature measurements of many items of equipment simultaneously; for example, a "fast scanner," using a cryogenically cooled detector, may indicate the temperature of a million discrete points in its field of view as it completes each scan

### 5.6.2 Disadvantages.

(1) Low accuracy for temperature measurements as such, and only moderate accuracy for temperature-difference measurements

(2) Susceptibility to interference from other sources of heat than the one being studied

(3) The need for an experienced operator and for careful analysis and interpretation of the data

(4) While not a serious limitation in areas where liquid nitrogen is readily available, the need for cryogenic cooling of the detectors in the faster responding scanning-image-type systems may be a disadvantage in some applications

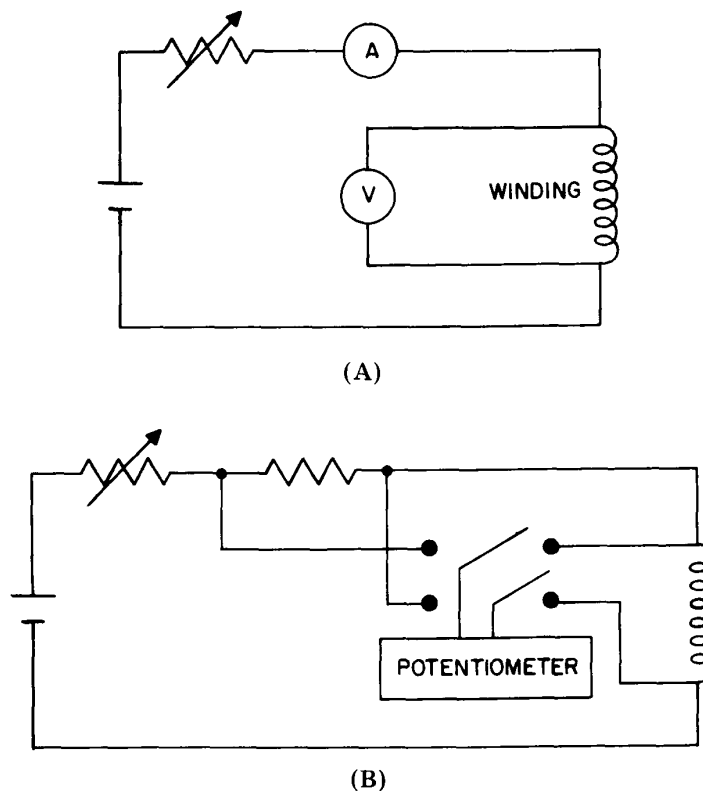

Fig 36  
Circuits for Resistance Measurements by Drop-of-Potential Method

## 6. Temperature Determination by the Change in Resistance Method

**6.1 General Principles.** If the resistance  $R_1$  of a copper or of an aluminum winding at a uniform temperature  $t_1$  is known, then the mean temperature  $t_2$  which produces a change in winding resistance to the value  $R_2$  can be found from the following equation, in which all temperatures are expressed in degrees Celsius:

$$t_2 = \frac{R_2}{R_1} (k + t_1) - k$$

where for copper, whose volume conductivity is 100 percent and whose temperature is between  $0^\circ\text{C}$  and  $125^\circ\text{C}$ ,  $k = 234.5$ ; and for aluminum, whose volume conductivity is 62 percent and whose temperature is between  $25^\circ\text{C}$  and  $125^\circ\text{C}$ ,  $k = 224.1$ . For copper of other than 100 percent volume conductivity,  $k$  is

given by the following equation:

$$k = \frac{25450}{n} - 20$$

and for aluminum of other than 62 percent volume conductivity,

$$k = \frac{15136.5}{n} - 20$$

where  $n$ , in each case, is the percent volume conductivity.

**6.2 Classification of Methods.** Two methods of measuring resistance are commonly used, namely, the drop-of-potential method and the bridge method. Each of these requires the use of direct current. Bridge methods are generally preferred because of their accuracy and convenience. They are especially recommended for use in temperature-change determinations.

**6.2.1 Drop-of-Potential Method.** Using the connections in Fig 36(A), simultaneous read-

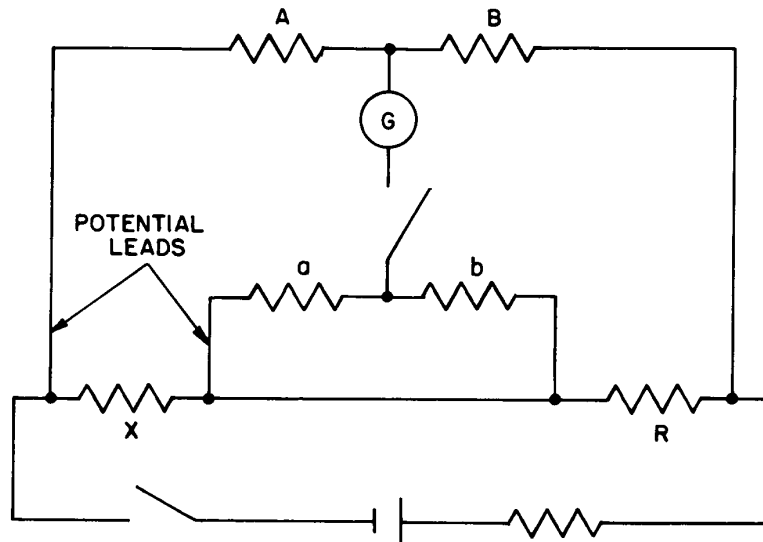

Fig 37  
Kelvin Bridge Circuit

ings are taken of current and voltage. The required resistance is calculated from the readings, in accordance with Ohm's law,

$$R = \frac{E}{I}$$

For the accuracy contemplated in this standard, the voltage and current may be determined by the use of indicating instruments of 1/4 percent accuracy. For more exacting work, or in the absence of suitable indicating instruments, ammeter A in Fig 36(A) should be a standard resistor in which the potential drop is measured by a high input-impedance digital voltmeter or a potentiometer. Voltmeter V should be a similar voltage-measuring instrument supplemented, if necessary, by a volt box. If preferred, a double-pole double-throw switch may be arranged to connect a suitable voltmeter or potentiometer alternately across the standard resistor and across the winding whose resistance is to be determined [Fig 36(B)].

If a regulated current source is used, changes in resistance and hence temperature can be determined from indications of a voltmeter connected across the winding only. Use of a recording voltmeter makes possible obtaining a continuous temperature record.

### 6.2.2 Bridge Methods.

**6.2.2.1 Wheatstone Bridge Method.** Resistances between 10 and 10 000  $\Omega$  can be measured with sufficient accuracy by the ordinary Wheatstone bridge. Special precautions with respect to contact and lead resistances are necessary for reliable measurements below 10  $\Omega$ .

The measured resistance includes that of the connecting leads between the bridge and the apparatus being tested. Therefore, the resistance of the connecting leads, if appreciable, must be subtracted from the total measured resistance.

**6.2.2.2 Bridges for Four-Terminal Resistance Measurements.** The magnitude of a low-valued resistor is readily defined if it is provided with separate current and potential terminals. Contact and lead resistances may introduce significant uncertainties in the measurement of resistors below 10  $\Omega$  in value unless they are defined and measured as four-terminal resistors.

The Kelvin bridge, known also as the double bridge, affords a means of comparing two resistors, R and X, each of which is provided with four terminals (see Fig 37). In a common form the sliders of the two ratio arms are operated by a single calibrated control. The rheo-

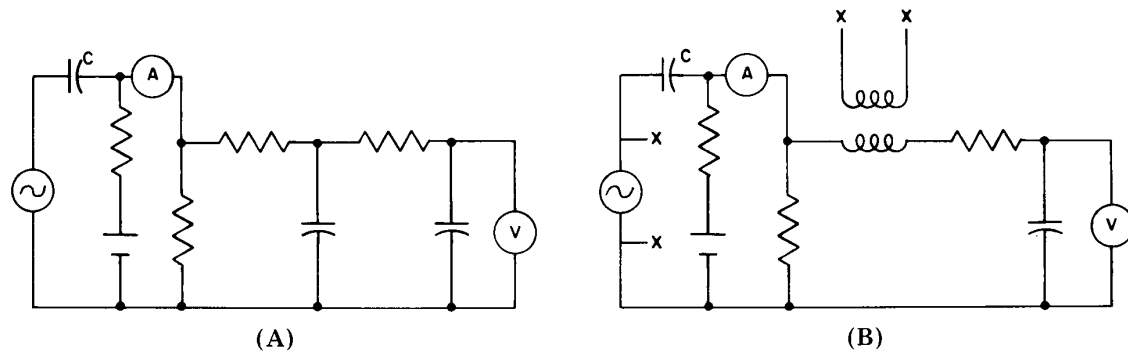

Fig 38

Circuits for Resistance Measurements by Drop-of-Potential Method with Circuit Energized

stats are so constructed that, for all slider positions,  $A/B = a/b$ . The bridge may be balanced by adjustment of the ratio arms, or of the standard resistor  $R$ , or by a combination of both. At balance, if the effect of resistance of the potential leads is ignored,

$$X = \frac{A}{B} R$$

While the effect of the resistances of the potential leads is small, it must always be considered. With a random relation between potential-lead resistances, the effect depends upon the resistance of the yoke  $\alpha$ . Yoke resistance is usually low, of the order of the resistance of  $R$  or  $X$ . It may consist largely of contact resistance. It is therefore not easily measured, nor in the successive connections required for measuring reference resistance and hot resistance is it likely to remain constant. Consequently, the effect of potential-lead resistances should be such that, regardless of the amount of yoke resistance, the error in temperature measurement cannot be excessive. One way of accomplishing this is to use such high resistance values in the ratio arms that the lead resistances are negligible. A more sophisticated (Wenner) method is discussed in [4].

The dc current comparator bridge (see [66]) is superior to the Kelvin bridge for high-accuracy resistance measurements in most, if not all, respects, but it is not yet available in a simple portable model suitable for measurements of the type under consideration in this section.

**6.2.3 Measurements on Energized Networks.** Temperature rise determination based

on dc measurements of the resistance of a network which is at the same time energized by ac power has several advantages. (1) The thermal behavior of the test item can be studied throughout the full heating time. (2) Meaningful measurements are possible, for example, in the case of motors whose winding connections are altered when the motor is stopped. (3) In a maximum temperature measurement, the uncertainty associated with rapid cooling following de-energization is eliminated.

There are two basic problems which must be resolved if satisfactory resistance measurements are to be made on energized systems. First, the large ac voltage on the resistor being measured must be prevented from affecting the resistance-measuring circuit, and second, the resistance-measuring circuit must not affect the normal ac characteristics of the system.

**6.2.3.1 Drop-of-Potential Method.** While a permanent-magnet moving coil (d'Arsonval) instrument may be expected to indicate the direct current through it with negligible error regardless of the presence of a large ac component, overheating of the ammeter shunt or voltmeter series resistance by the total rms current cannot be ignored. Electronic voltmeters in general will not read the dc voltage correctly in the presence of a large ac component. For these reasons reduction of the ac component by filtering as in Fig 38(A) or by a combination of filtering and injection of a compensating voltage [Fig 38(B)] is usually required.

The capacitor  $C$ , required to block the dc current in the circuits of Fig 38, must carry

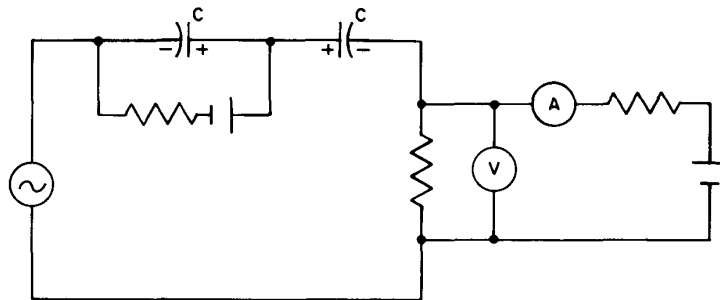

Fig 39  
Circuit with Capacitor Bias

the full ac load current without introducing appreciable voltage drop. An electrolytic capacitor can be used, but it must be polarized to prevent reversal of voltage on it, and the possible significance of dc leakage through it must not be overlooked. Depending on the ac requirements of the load, it may be possible to select a capacitor and a dc supply level such that the supply itself provides the necessary bias. In Fig 39 the bias is essentially independent of the supply.

**6.2.3.2 Seely's Method.** In the circuit of Fig 40, the capacitor  $C$  prevents the ac supply from shorting out the test item in the dc bridge. By means of the transformer  $T$ , an ac voltage is introduced into the dc bridge arm very nearly equal to but  $180^\circ$  out of phase with the ac voltage across the test item. Thus the problem of excessive ac current in the bridge circuit is minimized; however, since the bridge measures the resistance of the series combination of the test item and the secondary winding of transformer  $T$ , the resistance of the latter must be separately determined and an allowance made for it.

A modification of the Seely circuit which places the transformer winding resistance in one of the higher resistance arms of the bridge is shown in Fig 41(A). The  $L_1, C_1, L_2, C_2$  filter reduces the ac current flowing in the dc source. The same principle may be applied to the Kelvin double bridge as shown in Fig 41(B).

**6.2.3.3 Alternate Method.** An alternative to the techniques described in Section 6.2.3.2 may be used when the network to be tested is such that points of essentially equal ac potential are accessible or may be provided by the use of duplicate units. In such cases, di-

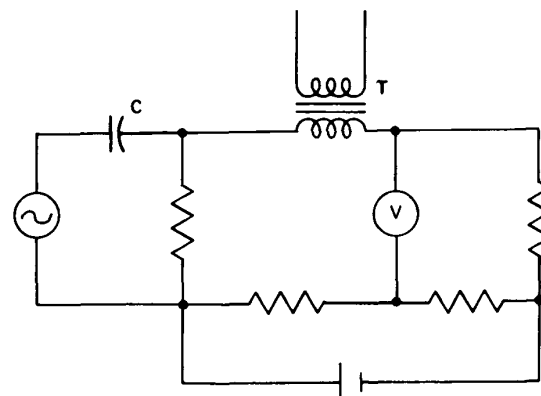

Fig 40  
Seely's Method

rect current may be injected, and bridge connections made, at these points. Thus, the need for a large capacitor, capable of carrying load current, and the relatively elaborate filtering of the preceding methods is eliminated. A typical test circuit is shown in Fig 42 (see [73]).

**6.2.4 Measurements on Recently De-energized Apparatus.** The average temperature rise of an energized transformer winding can be back-calculated either from a series of resistance readings obtained within a few minutes of de-energizing or, under certain conditions, from one such reading. The methods are covered in some detail in [76, section 6.8].

**6.2.4.1 Cooling Curve Method.** In this method, a curve is plotted upon suitable coordinate paper from the resistance-time data from several consecutive readings and is then extrapolated back to time zero.

**6.2.4.2 Empirical Method.** The back calculation for an oil-immersed winding can, in some cases, be based upon the resistance-time

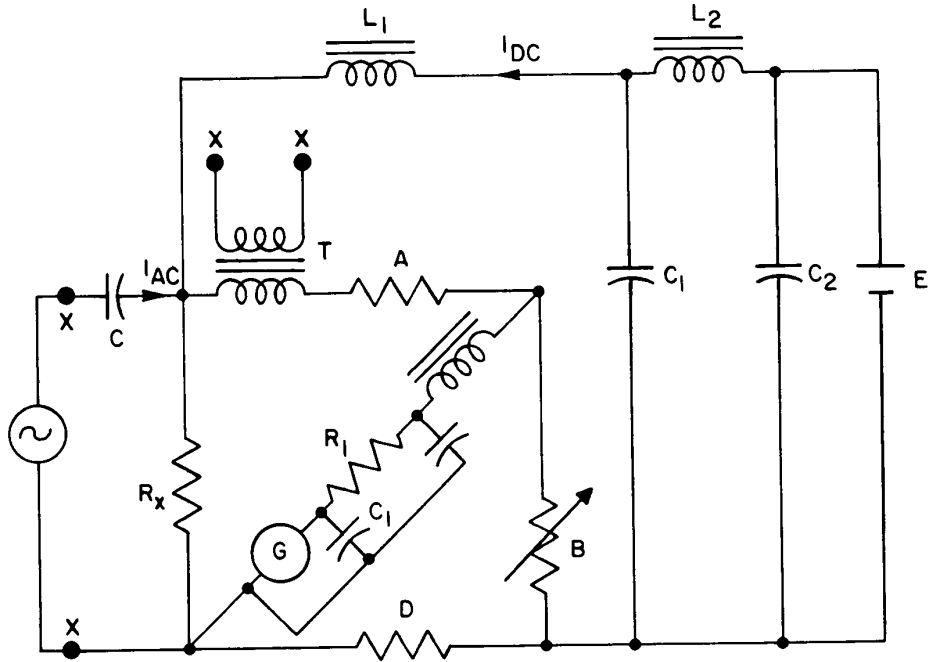

Fig 41 (A)  
Wheatstone Bridge Measurement with Potential Transformer in  
Bridge Arm Other than That with Unknown

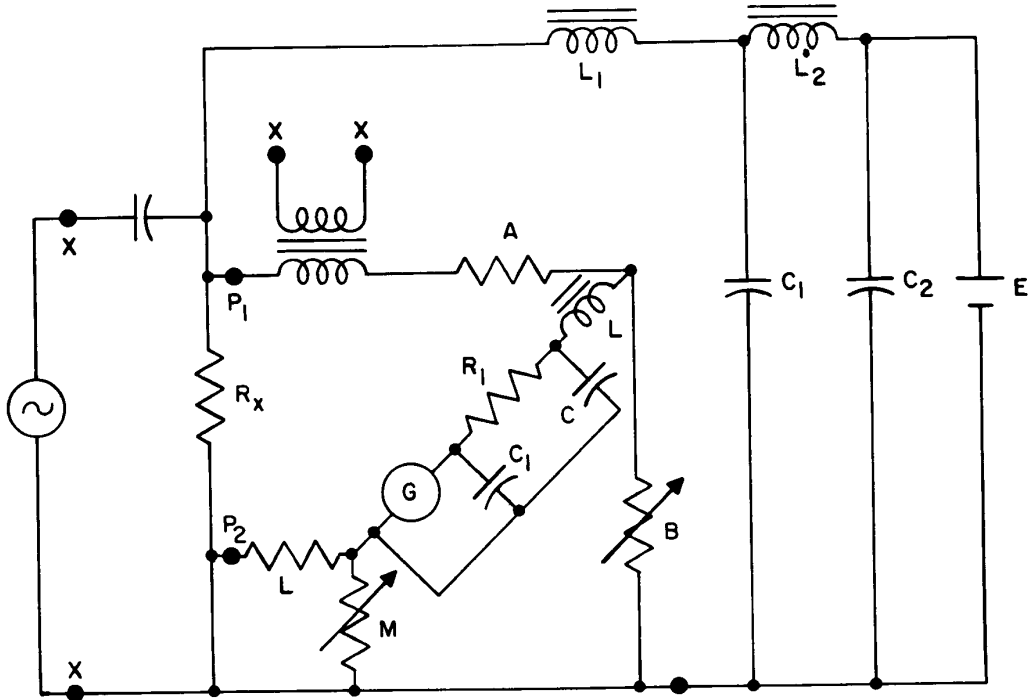

Fig 41 (B)  
Kelvin Bridge Measurement of Low-Valued Resistor Carrying AC Current

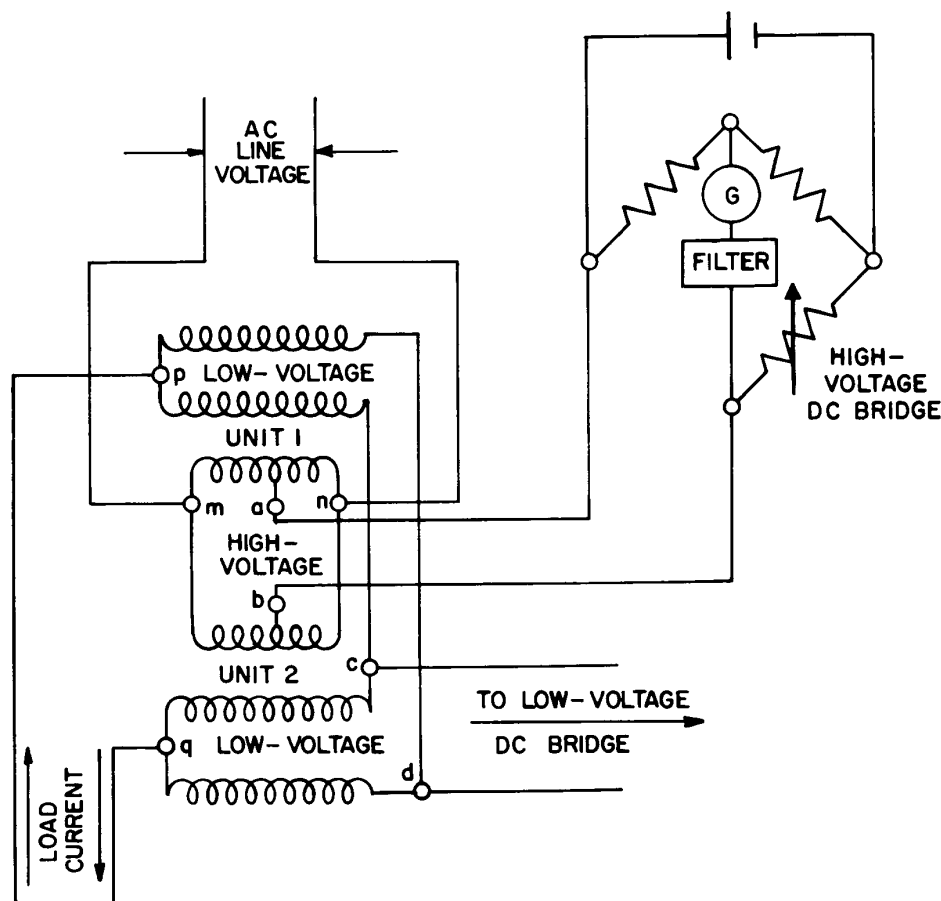

Fig 42

Circuit for Simultaneous Test of High-Voltage and Low-Voltage Winding Temperatures in Single-Phase Transformers Under Load and Line Voltage

data from a single reading, in conjunction with an appropriate correction factor related to the copper loss per pound of conductor.

### 6.3 Essential Considerations.

**6.3.1 Precautions in Determining Reference Temperature.** When the reference resistance  $R_1$  is measured, it is very important that the measurement of the winding temperature  $t_1$  be free from appreciable error. The following precautions should be observed.

(1) *Air-Cooled Apparatus:* The temperature of the windings may be assumed to be the average of the indications of several thermometers inserted between the coils with the thermometer bulbs as nearly as possible in actual contact with the metal conductors of the windings, provided that all temperatures so

obtained are within  $5^\circ\text{C}$  of the ambient temperature.

(2) *Oil-Cooled Apparatus:* The temperature of the windings may be assumed to be the same as that of the oil, provided that the windings have been under oil, without excitation and without current in them, for at least 3 h before the cold resistance is measured, and provided that the oil temperature is within  $10^\circ\text{C}$  of an ambient temperature which has not changed by more than  $5^\circ\text{C}$  during the previous hour.

**6.3.2 General Precautions in Resistance Measurements.** The value of measuring current used in determining the reference resistance should not exceed 15 percent of the rated current of the winding. Larger values of current, by heating the winding, may cause in-

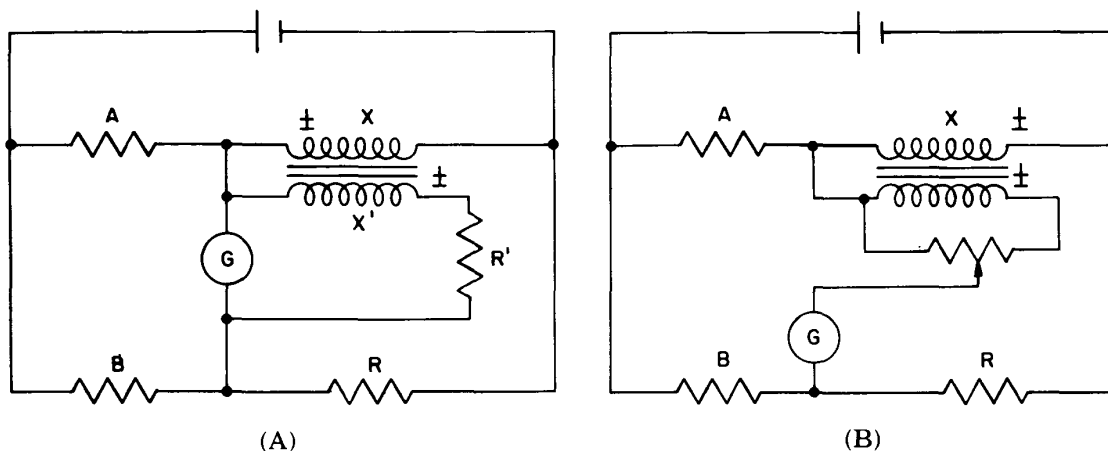

Fig 43  
Compensation of Wheatstone Bridge for Inductive Effects

accuracy. So far as heating is concerned, the measuring current used in determining hot resistance may well be of the order of the rated value; however, instrument errors are reduced if in both measurements the value of current is approximately the same. With voltmeters and ammeters, the latter consideration is more important than the maintenance of winding temperature. When potentiometers or bridges are being used, there is more delay in taking readings. It is then common practice to apply one of the techniques covered in Sections 6.2.4, 6.2.4.1, and 6.2.4.2 (with low test current). When these techniques are not feasible, there is an advantage in the use of a large measuring current in order to reduce the rate of cooling.

In order to avoid including in the measurement the resistance of contacts or of current-carrying leads, the potential and current connections to a winding should be independent of one another. It is essential that both the reference and the temperature determining resistance measurements be made between the same points. In measuring the reference resistance of a dc armature, the location of the two commutator segments that are selected to represent the armature terminals should be such that the segments are separated by about one-half the space between adjacent brush studs and that the winding circuits included between the segments do not contain any coils which are short-circuited by the brushes. The two segments chosen should be marked, and

when the hot resistance is measured they should be used again. In making connections to the commutator segments, sharp metal prods should be firmly pressed into the commutator risers or the exposed ends of the segments, so as to penetrate beneath any oxide film that may be on the surface.

The thermal emf may be appreciable compared to the potential drop across a low-resistance winding. In the drop-of-potential method, a tare potential reading, taken with no current in the winding, should be algebraically subtracted from the potential reading with current present. In bridge measurements, a balance should be obtained such that the galvanometer reading with the galvanometer key closed is the same whether the battery key is open or closed.

A galvanometer or voltmeter in a circuit which includes an inductive winding may be damaged by a rapid increase or decrease of the current in the winding. Common practice in making a bridge measurement of the resistance of an inductive winding is to short the winding terminals prior to disconnecting the dc source from the bridge. Alternatively, protection may be obtained by temporarily shorting the terminals of the galvanometer or voltmeter itself.

Readings should not be taken during the period when they are affected by the electric transient in inductive windings. This period may be shortened by initially applying to the winding a voltage greater than that required

under steady-state conditions to maintain the desired value of current. This may be accomplished automatically by connecting in series with the source of voltage a metal-filament incandescent lamp. The voltage rating of the lamp should equal approximately that of the source; both should be several times as large as the voltage desired at the measuring circuit. The power rating of the lamp should equal approximately the product of the desired measuring current and the voltage of the source. The current in a winding reaches its steady-state value most quickly if all other windings on the same core are open-circuited.

In measuring the resistance of two or more windings of a transformer, the relative polarity of the measuring leads and the transformer terminals should be so maintained that the residual magnetism in the core is not reversed. This lessens the time required for the direct current to reach a constant value. Inductive effects of a winding can be eliminated by compensation derived from another winding on the same core. Fig 43 shows such compensation applied to the Wheatstone bridge method. For elimination of the inductive effect, it is necessary to connect the compensating winding to the galvanometer in opposition and to adjust the resistance of the compensating circuit so that the resistance ratio  $(R' + X')/(R + X)$  is approximately equal to the turns ratio of the compensating winding to the winding being measured ( $N_x'/N_x$ ). If  $N_x'/N_x > 1$ , the compensating winding may alternatively be introduced as shown in Fig 43(B). The compensating circuit acts as a shunt across the galvanometer, somewhat reducing sensitivity.

#### 6.4 Advantages and Disadvantages of the Change in Resistance Method of Temperature Determinations.

##### 6.4.1 Advantages.

- (1) No approximation to actual conditions is required
- (2) The test object is at the same time the sensor, and thus the question of location of the sensor does not arise

##### 6.4.2 Disadvantages.

- (1) The indicated temperature is the average temperature of the network whose resistance is measured; consequently, the existence of localized "hot spots" may not be revealed

- (2) When measurements are made on energized networks, some hazard to personnel and instruments is inevitable, and appropriate protective measures are required

- (3) The method is best suited for measurements of temperature change

## 7. Temperature-Sensitive Materials

**7.1 Principles of Operation.** The melting of a crystalline solid occurs at a definite temperature which is essentially independent of normal fluctuations in atmospheric pressure. Thus the fusion of a solid of known melting point may be used as an indication of the attainment of that temperature.

There also exist a number of pigments which undergo a definite change in color at well-defined temperatures, usually due to partial decomposition of the pigment. Some complex compounds or mixtures undergo several successive changes at a sequence of temperatures, that is, a material may change from an original blue to green then yellow and finally brown, as its temperature is increased.

**7.2 Classification.** As suggested in Section 7.1, temperature-sensitive materials for use as temperature indicators may be classified as fusible (melting-point) or color-changing (pigment) types.

**7.2.1 Fusible Indicators.** Fusible indicators are available in a variety of forms, including solid sticks (crayons), pellets, liquids, and lacquer-coated paper decals. In the liquid form the fusible material, in finely ground form, is suspended in a volatile vehicle which quickly evaporates after the liquid is applied with a brush or as a spray, leaving a coating of the fusible solids.

When the crystalline material melts, it changes from a "dry" to a "wet" appearance and for most indicators the return to solid form which occurs as the temperature is again reduced results in a texture quite different from the original dry appearance, thus leaving permanent evidence that the precalibrated temperature has been attained or exceeded. In one of the "decal" types, the white or light-colored coating of the fusible material is absorbed, when it melts, by the dark underlying paper, with a resultant permanent color change, the active portion of the decal chang-

ing from white to black, as evidence that the precalibrated temperature has been reached or exceeded.

**7.2.2 Color-Changing (Pigment-Type) Indicators.** Color-changing (pigment-type) indicators are usually carried in a solvent which is brushed or sprayed onto the surface being monitored. Weather and oil-resistant temperature-sensitive color-changing paints are available for outdoor and special applications.

### 7.3 Characteristics.

**7.3.1 Range.** Temperature-sensitive materials are available with precalibrated temperature ratings systematically spaced at frequent intervals over the range 38 to 1760°C with special types suitable for special environmental conditions (for example, reducing atmospheres) up to the order of 1500°C.

**7.3.2 Precision and Accuracy.** The color-changing indicators are normally considered useful only as indicators of approximate temperature levels, although if sufficient care is exercised they are capable of providing indication of the maximum temperature reached with an accuracy of 10 to 15°C.

The fusible types can usually be relied upon to an accuracy of about 1 percent of the temperature being determined over the normal range 38 to 1760°C.

**7.3.3 Response Time.** Color changes in the color-changing types occur as functions of time through transition ranges of temperature. The effect may be observable within a few seconds but progressive changes may continue for hours, even if the temperature is maintained unvarying. A reference or standard "exposure time" frequently accepted is 1 min.

The fusible type may exhibit a response time of a fraction of a second; however, with both types the response time is dependent on the mass of material to be heat-converted; therefore, where quick response is required, the coating should be thin or the pellet small.

**7.3.4 Stability.** While most of the temperature-sensitive materials available commercially are sufficiently stable to withstand extended storage periods, it must be recognized that prolonged storage at elevated temperatures (although below the critical temperature), at high humidities, or in contaminated atmospheres, may be expected to have deleterious effects in some cases.

**7.4 Application and Installation.** Since temperature-sensitive materials in general only provide an indication that a specified temperature has been attained or exceeded, they can be used to determine the actual temperature reached only by a bracketing procedure. That is, several indicators, differing only slightly in their precalibrated temperatures are applied to the surface whose temperature is to be determined. The temperature reached is thus established as lying somewhere between the highest temperature rating which reacted (by melting or changing color) and the next higher unaffected temperature rating.

A temperature-sensitive coating indicates its own temperature. This, of course, actually only approximates the temperature which the surface would have reached in its absence. In general, the approximation can be improved by reducing the size, in thickness and area, of the sensor applied; however, where radiation exchange at the surface is significant the error may, even with this precaution, be serious.

### 7.5 Advantages and Disadvantages.

#### 7.5.1 Advantages.

- (1) The possibilities for a broad scope of information with a minimum of effort
- (2) Ease of obtaining information on temperature distribution over a surface
- (3) Simplicity of application, which permits this method to be entrusted to relatively low-skilled personnel

#### 7.5.2 Disadvantages.

- (1) Limited accuracy
- (2) Necessity for direct visual observation of the surface being monitored
- (3) Limitation to surface measurement applications (except in the special cases which permit embedding a miniature temperature-indicating pellet in a drilled cavity of the work piece)

## 8. Measurement of Ambient Temperature

**8.1 General.** In general, ambient temperature is the temperature of the medium that is used, directly or indirectly, for cooling apparatus. More specific definitions, for some common types of equipment readily classified by cooling method, are given in IEEE Std 1-1969. For some other equipment, the appro-

appropriate definition of ambient temperature may be available only as a part of the standards for that particular apparatus. Rules for the establishment of standard ambient temperatures for rating purposes or to define standard service conditions are outside the scope of this document and will be found in IEEE Std 1-1969 and specific apparatus standards.

Methods for determining the value of ambient temperature to be reported for a given test may be given in apparatus standards. Where such standards do not apply, it may be taken as the mean reading of the ambient temperatures observed at equal time intervals during the last quarter of the test, provided that, during that time, the average of no set of simultaneous readings differs from the average of any other set by more than 5° C.

In order to determine the temperature rise of apparatus under specific test conditions, ambient temperature is to be subtracted from the measured temperature of the apparatus. Since it is the temperature rise, rather than the measured apparatus temperature, which is the basis of rating and calculation of thermal performance under other load and ambient conditions, accurate measurement of ambient temperature frequently is as important as that of apparatus temperature.

While sources of error in ambient-temperature measurement, and appropriate methods of minimizing them, will vary widely with different types of apparatus, the following general observations may be helpful.

**8.2 Sources of Error in Ambient-Temperature Measurements.** Ambient temperature may be measured by whichever of the types of sensors described elsewhere in this standard is most appropriate for the situation. The most commonly used are liquid-in-glass thermometers and thermocouples. Whatever form of sensor is used, the errors characteristic of that type must be considered and all practical efforts made to minimize them.

The cooling medium generally is not at a uniform temperature throughout. It is essential that care be taken to take measurements in a sufficient number of locations to insure obtaining a representative average. In testing apparatus where the flow of coolant is forced or directed, the sensors should be located, subject to the limitations imposed by other sources of error, as near as is practical to the

point of entrance to, or impact upon, the apparatus on test.

Depending on the type of apparatus being tested and the type of ambient-temperature sensors employed, errors may be introduced by external thermal radiation and drafts. Contact of the sensors with bodies other than the cooling medium should be minimized, to avoid heat transfer between them, with an exception noted in Section 8.2.1.

Specific sources of error peculiar to various cooling methods, and means of minimizing them, are given in the following sections.

**8.2.1 Self-Ventilated Apparatus.** Self-ventilated apparatus depends entirely on the surrounding air for cooling. Here, ambient temperature should be measured by sensors placed at such points around and at half the height of the apparatus that they effectively measure the temperature of the air surrounding the apparatus. While four sensors are generally used, more or less may be appropriate in particular circumstances.

In most cases, the sensors may be placed at a horizontal distance of 1 to 2 m from the apparatus. They should be protected from drafts and thermal radiation by the use of suitable reflecting baffles which do not unduly restrict contact of the sensor with the air whose temperature is to be measured. The apparatus on test, power supplies and control equipment for them, and space heaters in the test area are among the common sources of thermal radiation which may cause serious errors in the readings of sensors.

In order to avoid errors due to the time lag between the temperature of large apparatus and variations in ambient air temperature, all reasonable precautions must be taken to reduce these variations. When the cooling-air temperature is subject to such unavoidable variations that error in the temperature rise might result, sensors of cooling-air temperature should be immersed in a container of a suitable liquid, such as oil. The type of liquid, its amount, and the size, shape, and material of the container should be selected so that the thermal time constant of the assembly will approximate that of the apparatus on test. Some apparatus test standards place a limit on the degree of approximation which is permissible.

At one time, measurement of the temperature of a duplicate of the unit on test, but

carrying no load, was considered to be an appropriate method of measuring ambient temperature. Recent tests, however, have shown that this technique is not sufficiently accurate in many cases, and immersion of ambient-temperature sensors in a suitable container of liquid, as described previously, is preferred.

**8.2.2 Enclosed Ventilated Apparatus.** For ventilated apparatus, so enclosed that all the air circulating through it is drawn or forced through ducts from a distance, ambient-temperature sensors should be located at the intake of the apparatus, to avoid errors caused by duct heating. If that location results in appreciable radiation error, the error frequently may be reduced by enclosing each or all of the sensors in an open-ended reflecting cylinder, whose axis is parallel with the direction of air flow. Where this is impractical, a compromise location which will minimize the total error should be selected. In any case, the number and spacing of the sensors should be such as to insure securing a representative average temperature indication.

**8.2.3 Liquid-Cooled Apparatus.** This section applies to apparatus in which the coolant is derived from an external source. It does not apply to apparatus in which self-contained coolant is circulated between the heat source and an integral or remote heat exchanger. It is further assumed that the cooling liquid is the principal heat sink, other means of heat rejection being negligible by comparison. Where these conditions prevail, ambient temperature may be measured by sensors placed in suitable wells (Section 3.4), installed at the inlet of the primary cooling-liquid line so as to measure the temperature of the entering liquid.

**8.3 Ambient-Temperature Measurements in Service.** The foregoing sections apply primarily to ambient-temperature measurements made in the laboratory. Frequently, however, it is desirable to study the thermal performance of apparatus in simulated or actual service, which usually requires ambient-temperature measurements. Because of the extreme variety of in-service conditions which may be encountered, it is impractical to provide specific guides for all situations which may be encountered. For this reason, Sections 8.3.1 through 8.3.3 are to be construed as informative only. The selection of methods of measurement, and the interpretation of the data

collected, must be governed by sound judgment in the light of prevailing conditions.

**8.3.1 Outdoor Apparatus.** Most apparatus designed for outdoor use is self-ventilated and rejects heat primarily by a combination of radiation and convection. When tested in the laboratory, the surroundings of the unit on test are assumed to be at a temperature approximately that of the ambient air temperature, so radiation and convection occur to a common ambient. Outdoors, however, the same unit may be surrounded by an environment including earth, sky, and adjacent structures, all of which may be at different temperatures, and none of which is necessarily at ambient still-air temperature.

A major complication in outdoor temperature measurements is solar radiation, both direct and reflected, which will affect both the temperature of the apparatus on test and that of ambient-temperature sensors, but generally by different amounts. Sensors may, and should, be protected by reflecting surfaces which do not hinder air flow about the sensors. Where practical, an approximation of the effect of solar radiation on the test unit may be obtained by measuring the temperature rise of a duplicate unloaded unit. [See IEEE Std 144-1971 (ANSI C37.24-1971), Guide for Evaluating the Effect of Solar Radiation on Outdoor Metal-Clad Switchgear.]

An additional source of error is wind, which also may affect the ambient-temperature sensors and the unit on test differently. No practical method of eliminating these effects without defeating the objectives of the test has yet been devised. Measurements on an idle unit, as used to determine the effect of solar radiation, will be helpful, but corrections so obtained will not generally be applicable for wind velocities and directions other than those obtaining when the readings are taken.

Since the cited sources of error vary with time, it is desirable to continue outdoor tests for as long as is practical. Results obtained over an extended period of time may then be analyzed to minimize the time-variant effects. The final results will not, even then, be of an accuracy comparable to that obtainable in a laboratory, but may provide very useful data indicating the probable thermal performance of the apparatus under typical and extreme environmental conditions.

**8.3.2 Confined Apparatus.** Frequently, apparatus may be installed in such a way as to restrict the flow of cooling air about it (for example, vault-type transformer installations). This restricted air flow will, in general, reduce cooling and consequently increase temperature rise. Where the apparatus on test rejects an appreciable amount of heat by radiation, the temperature of the confining structure may also exert a major effect on total heat loss. If this temperature differs markedly from that of the incoming cooling air, the total heat rejection may thus be to two effective ambient temperatures. Consequently, it is desirable to measure both the incoming air temperature and that of the confining structure if performance under other load and ambient conditions is to be computed from the test data.

**8.3.3 Buried Apparatus.** Heat rejection from equipment completely buried in the earth is a function of the temperature, heat capacity, and thermal conductivity of the adjacent earth. Consequently, ambient-temperature measurements should be made by the use of one or more sensors, embedded in the earth to the average depth of the apparatus on test, and located at a distance sufficient to be uninfluenced by the heat generated by the apparatus itself. Tests should be continued long enough, days or weeks, to ascertain that a stable temperature rise has been established. Further, since the thermal conductivity of soil is profoundly affected by its moisture content, tests should be continued long enough to observe the effect of changes in conductivity due to variations in rainfall, flow of subterranean water, and thermal migration of moisture.

## 9. Bibliography

### 9.1 General.

[1] IEEE Std 100-1972, (ANSI C42.100-1972), Dictionary of Electrical and Electronics Terms.

[2] *Precision Measurement and Calibration — Temperature*, NBS Special Publication 300, vol 2, National Bureau of Standards, Washington, D. C., 1968.

[3] American Institute of Physics. *Temperature, Its Measurement and Control in Science and Industry*, vol 1. New York: Reinhold Publishing Corporation, 1941.

[4] *Ibid*, vol 2, 1955.

[5] *Ibid*, vol 3, 1962.

[6] BENEDICT, R. P. Review of practical thermometry. ASME<sup>6</sup> Paper 57-A-203, 1957.

[7] RALL, D. L., and HORNBAKER, D. R. Taking meaningful temperature measurements. *Instrumentation Technology*, Oct 1967, pp 63 — 68.

[8] *Temperature Measurement; Power Test Codes Supplement on Instruments and Apparatus*, pt 3, ASME, Publication PTC 19.3-1961, 1961.

[9] ASTM<sup>7</sup> E1-71, Specifications for ASTM Thermometers.

[10] ASTM E344-68, Definitions of Terms Relating to Temperature Measurement, 1968.

[11] ASHRAE<sup>8</sup> 41-66, Part I, Measurements Guide, Section on Temperature Measurements, 1966.

[12] EIA<sup>9</sup> RS-249 (NEMA SK55-1961), Temperature Measurements by Users of Silicon Rectifiers, 1961.

[13] ISA<sup>10</sup> RP25.1, Materials for Instruments in Radiation Service, 1957.

[14] SAMA<sup>11</sup> RC 17-10, Bushings and Wells for Temperature Sensing Elements, 1963.

[15] SAE<sup>12</sup> ARP 175, Temperature Measurement, Well Insert Type, 1948.

[16] ISA S26, Dynamic Response Testing of Process Control Instrumentation, 1968.

[17] ISA RP20.1 and 20.2, Instrument Specification and Test Form Pads. (Available for Filled System, Thermocouple, Resistance and Bimetallic Thermometers, and for Potentiometers and Bridges.)

[18] Instrument Society of America. *Temperature, Its Measurement and Control in Science and Industry*, vol 4. Pittsburgh, PA: Instrument Society of America, 1972.

<sup>6</sup>American Society of Mechanical Engineers, 345 East 47 Street, New York, N. Y. 10017.

<sup>7</sup>American Society for Testing and Materials, 1916 Race Street, Philadelphia, Pa. 19103.

<sup>8</sup>American Society of Heating, Refrigerating, and Air Conditioning Engineers, Inc., 345 East 47 Street, New York, N. Y. 10017.

<sup>9</sup>Electronic Industries Association, 2001 Eye Street N. W., Washington, D.C. 20006.

<sup>10</sup>Instrument Society of America, 530 William Penn Place, Pittsburgh, Pa. 15219.

<sup>11</sup>Scientific Apparatus Makers Association, 1140 Connecticut Ave. N. W., Washington, D.C. 20036.

<sup>12</sup>Society of Automotive Engineers, 2 Pennsylvania Plaza, New York, N. Y. 10001.

### 9.2 Liquid-in-Glass Thermometers.

- [19] GUILLAUME, C. E. *Traite Practique de la Thermometrie*. Paris: Gauthier-Villars et Fils, 1889, p 99.
- [20] HALL, J. A., and LEAVER, V. M. The design of mercury thermometers for calorimetry. *Journal of Scientific Instruments*, vol 36, 1959, p 183.
- [21] SWINDELLS, J. F. *Calibration of Liquid-in-Glass Thermometers*, NBS Monograph 90, National Bureau of Standards, Washington, D. C., 1965.
- [22] BUSSE, J. Liquid-in-glass thermometers, in American Institute of Physics. *Temperature, Its Measurement and Control in Science and Industry*, vol 1. New York: Reinhold Publishing Corporation, 1941, pp 228 — 255.
- [23] ASTM E77-66, Standard Method for Inspection, Test and Standardization of Liquid-In-Glass Thermometers, 1966.
- [24] SAMA LA 1, Laboratory-Type, Liquid-in-Glass Thermometers, 1965.
- [25] SAMA RC 7-1, Liquid-in-Glass Industrial Thermometers, 2nd ed, 1962.
- [26] ISO<sup>13</sup> R651-1968, Solid-Stem Calorimeter Thermometers.
- [27] ISO R652-1968, Enclosed-Scale Calorimeter Thermometers.
- [28] ISO R653-1968, Long Solid-Stem Thermometers for Precision Use.
- [29] ISO R654-1968, Short Solid-Stem Thermometers for Precision Use.
- [30] ISO R655-1968, Long Enclosed-Scale Thermometers for Precision Use.
- [31] ISO R656-1968, Short Enclosed-Scale Thermometers for Precision Use.

### 9.3 Filled-System Thermometers.

- [32] Bibliography of Bourdon tubes and Bourdon-tube gages. ASME Paper 53-IRD-1. (This paper gives reference to 142 papers on this subject.)
- [33] SAMA Re 6-10-1955.
- [34] SAMA RC 6-10, Filled System Thermometers, 2nd ed, 1963.

### 9.4 Bimetallic Thermometers.

- [35] SAMA RC4-10-1955, Bimetallic Thermometers.

- [36] SAMA PMC-4-1, Bimetallic Thermometers, 2nd ed, 1962.

### 9.5 Thermocouple Thermometers.

- [37] ROESER, W. F. Thermoelectric thermometry. *Journal of Applied Physics*, vol 11, no 6, June 1940, pp 388 — 407.
- [38] American Institute of Physics. *Temperature, Its Measurement and Control in Science and Industry*, vol 1. New York: Reinhold Publishing Corporation, 1941, p 180.
- [39] ROESER, W. F., and LONGBERGER, T. S. L. *Methods of Testing Thermocouples and Thermocouple Materials*, NBS Circular 590, National Bureau of Standards, Washington, D. C., 1958.
- [40] CALDWELL, F. R. Temperatures of thermocouple reference junctions in an ice bath. *Journal of Research of the National Bureau of Standards*, vol 69C, no 2, Apr — June 1965, pp 95 — 101.
- [41] DIKE, P. H. *Thermoelectric Thermometry*. Philadelphia, PA: Leeds and Northrup Company, 1958.
- [42] FINCH, D. I. General principles of thermoelectric thermometry, in American Institute of Physics. *Temperature, Its Measurement and Control in Science and Industry*, vol 3. New York: Reinhold Publishing Corporation, 1962, pp 3 — 32.
- [43] Thermoelectric thermometry, in American Institute of Physics. *Temperature, Its Measurement and Control in Science and Industry*, vol 3, pt 2. New York: Reinhold Publishing Corporation, 1962, pp 3 — 294.
- [44] *Thermocouple Materials*, NBS Monograph 40, National Bureau of Standards, Washington, D. C., 1962.
- [45] ANSI<sup>14</sup> C96.1-1964 (R1969), Temperature Measurement Thermocouples.
- [46] ASTM E230-68, Standard Temperature-Electromotive Force (EMF) Tables for Thermocouples, 1968.
- [47] ASTM E235-67, Specification for Thermocouples, Sheathed Type K, for Nuclear or for High Reliability Applications, 1967.
- [48] SAMA RC 8-10, Thermocouple Thermometers (Pyrometers), 2nd ed, 1963.
- [49] SAMA RC 9-11, Temperature-emf Relation for Iron-Constantan Thermocouples, 1956.

<sup>13</sup>International Standards Organization. ISO Standards are obtainable from the American National Standards Institute, 1430 Broadway, New York, N. Y. 10018.

<sup>14</sup>American National Standards Institute, 1430 Broadway, New York, N. Y. 10018.

- [50] SAE AIR 46, Preparation and Use of Chromel-Alumel Thermocouples for Turbojet Engines, 1956.
- [51] ISA RP25.1, Materials for Instruments in Radiation Service, 1957, p 11.
- [52] ISA S26, Dynamic Response Testing of Process Control Instrumentation, 1968, p 9.
- [53] ASTM STP 470, Manual on Use of Thermocouples in Temperature Measurements.
- [54] ZYSK, E. D., and ROBERTSON, A. R. Thermocouples for above 1,500°C. *Instrumentation Technology*, Nov 1971, pp 30 – 38.
- [55] REPKO, L. L. Recovery factors for various test thermocouples. *Design News Reference Manual*. Detroit, MI: Rogers Publishing Company, 1953, pp 294 – 295.
- [56] BLISS, P., and MORGAN, R. K. Errors in temperature measurement. *Instrumentation Technology*, Mar 1971, pp 51 – 54.

#### 9.6 Resistance Thermometers.

- [57] MUELLER, E. F. Precision resistance thermometry, in American Institute of Physics. *Temperature, Its Measurement and Control in Science and Industry*, vol 1. New York: Reinhold Publishing Corporation, 1941, pp 162 – 179.
- [58] STIMSON, H. F. Precision resistance thermometry and fixed points, in American Institute of Physics. *Temperature, Its Measurement and Control in Science and Industry*, vol 2, New York: Reinhold Publishing Corporation, 1955, pp 141 – 168.
- [59] Resistance thermometry, in American Institute of Physics. *Temperature, Its Measurement and Control in Science and Industry*, vol 3, pt 2. New York: Reinhold Publishing Corporation, 1969, pp 295 – 368.
- [60] EIA RS-309 [ANSI C83.27-1968 (R1972)], General Specification for Thermistors, Insulated and Non-Insulated, 1965.
- [61] EIA RS-337, (ANSI C83.28-1968), General Specification for Glass Coated Thermistor Beads and Thermistor Beads in Glass Probes and Glass Rods (Negative Temperature Coefficient), 1967.
- [62] SAMA RC 5-10, Resistance Thermometers, 2nd ed, 1963.
- [63] SAMA RC 21-4-1966, Temperature-Resistance Values for Resistance Thermometer Elements of Platinum, Nickel and Copper, 1966.
- [64] KUSTERS, N. L., and MACMARTIN, M. P. A direct-current comparator bridge for resistance thermometry. *IEEE Transactions on Instrumentation and Measurement*, vol IM-19, no 4, 1970, pp 291 – 297.
- [65] CUTKOSKY, R. D. An ac resistance thermometer bridge. *Journal of Research of the National Bureau of Standards*, vol 74C, no 1 and 2, 1970, pp 15 – 18.
- [66] KUSTERS, N. L. and MACMARTIN, M. P. A direct-current comparator ratio bridge for four-terminal resistance measurements. *IEEE Transactions on Instrumentation and Measurement*, vol IM-15, no 4, Dec 1966, pp 212 – 220.
- [67] THOMPSON, A. M. AC bridge for platinum resistance thermometry, *Proceedings of the Institute of Electrical Engineers*, vol 118, no 11, Nov 1971, pp 1662 – 1666.
- [68] Instrument Society of America. *Temperature, Its Measurement and Control in Science and Industry*, vol. 4. Pittsburgh, PA.: Instrument Society of America, 1972, Section IV: Resistance and electronic thermometry and Section VII: Bridges and potentiometric methods for temperature measurement.

#### 9.7 Infrared-Radiation Thermometer Systems.

- [69] PECK, R. H. Thermal inspection pinpoints hot spots before troubles arise. *Electric Light and Power*, Feb 1969, pp 67 – 69.
- [70] WANK, M. R. Application pointers for infrared thermometry. *Instrumentation Technology*, Jan 1969, pp 43 – 45.
- [71] LEFTWICH, R. F. and ORDWAY, G. B. Optical thermal testing — A state of the art review. *International Journal of Non-destructive Testing*, vol 2, 1970.
- [72] Instrument Society of America. *Temperature, Its Measurement and Control in Science and Industry*, vol 4. Pittsburgh, PA: Instrument Society of America, 1972, Section IIE: Radiation thermometry — Thermal mapping and scanning.

#### 9.8 Temperature Determination by the Change in Resistance Method.

- [73] LOCKIE, A. M., and STEIN, G. M. Measuring transformer winding temperatures continuously with the transformer carrying load. *Transactions of the AIEE*, vol 67, pt 2, 1948, pp 1608 – 1620.

[74] JOHNSON, G. J. Determination of temperature rise of energized transformers by the resistance change method. *IEEE Transactions on Power Apparatus and Systems*, vol PAS-89, no 2, Feb 1970, pp 336 – 340.

[75] IEC Publication 297-1969, Measurement of the Winding Resistance of an AC Machine During Operation at Alternating Voltage.

[76] IEEE Std 262-1973 (ANSI C57.12.90-1973). Test Code for Distribution, Power, and Regulating Transformers.

#### 9.9 Temperature-Sensitive Materials.

[77] KASANOF, D. R., and KIMMEL, E. Recent developments in fusible temperature indicators, in American Institute of Physics. *Temperature, Its Measurement and Control in Science and Industry*, vol 3, pt 2. New York: Reinhold Publishing Corporation, 1941, pp 1005 – 1007.

[78] BAKER, H. D., RYDER E. H., and BAKER, N. H. *Temperature Measurements in Engineering*. New York: John Wiley and Sons, Inc, 1961, pp 188 – 190.

#### 9.10 Measurement of Ambient Temperature.

[79] BEAVERS, M. F. Measurement of ambient-air temperature during temperature test

on transformers. *Transactions of the AIEE (Power Apparatus and Systems)*, vol 18, Dec 1959, pp 1021 – 1029.

[80] Edison Electric Institute. *Underground Systems Reference Book*. New York: Edison Electric Institute, 1957, ch 10, sec B.

[81] IEEE Std 1-1969, General Principles for Temperature Limits in the Rating of Electric Equipment.

[82] IEEE Std 144-1971 (ANSI C37.24-1971), Guide for Evaluating the Effect of Solar Radiation on Outdoor Metal-Clad Switchgear.

[83] IEC 68-2-14-1960, Test N: Change of Temperature (Supplement to IEC 68, Basic Environmental Testing Procedures).

#### 9.11 Other Temperature-Measuring Techniques.

[84] ANDERSON, A. C., PETERSON, R. E., and ROBICHAUX, J. E. Magnetic thermometry. *Review of Scientific Instruments*, vol 41, 1970, p 528.

[85] APPEL, J. H. Acoustical thermometry. *Review of Scientific Instruments*, vol 33, 1962, p 428.

[86] BRANCA, F. P. New high-sensitivity quartz thermometer. *Review of Scientific Instruments*, vol 38, 1967, p 1644.